

414C

Stratus 4 Post 14,000 LBS
Capacity Pneumatic Safety Lock
Release Compact Car Lift

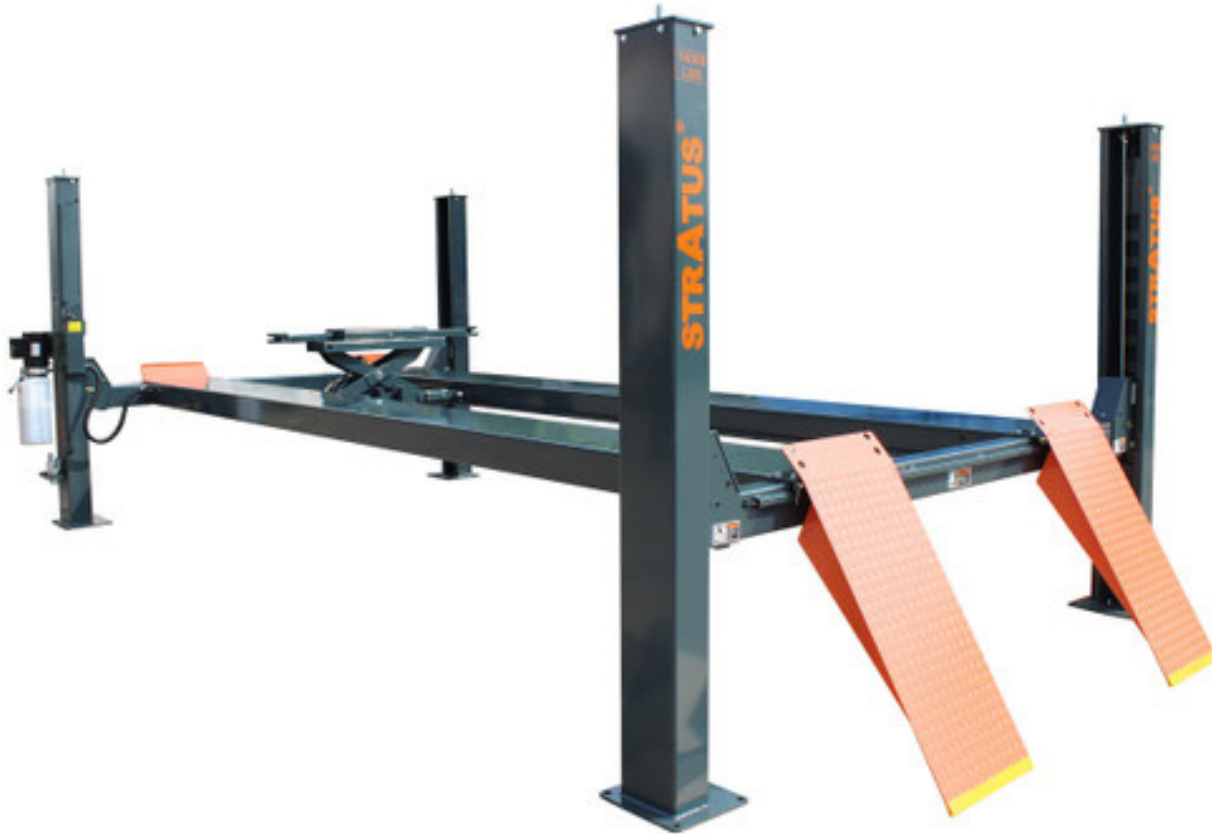

WWW.STRATUSAUTOEQUIP.COM

STRATUS
auto equipment



512-640-9896
8413 Calibration Ct
College Station, TX 77845
sales@stratusautoequip.com

TECHNICAL

Model	414C
Capacity	14,000 LBS
Overall Height - A	91 1/2" (2324 MM)
Overall Width - B	144 9/16" (3672 MM)
Overall Length w/ ramps - C	253 1/8" (6430 MM)
Overall Length w/o ramps - D	213 3/8" (5420 MM)
Max lifting height - E	73 7/16" (1865 MM)
Min lifting height - F	7 1/2" (191 MM)
Clearance Height - G	65 15/16" (1675 MM)
Lifting Time	~50 SEC
Width between columns - H	107 9/16" (2732 MM)
Drive Thru - I	82 1/2" – 86 7/16" (2096 MM – 2196 MM)
Runway width - J	20" (508 MM)
Runway Length - K	203 1/8" (5160 MM)
Between Runways - L	42 1/2" – 46 7/16" (1080 MM – 1180 MM)
Motor	4 HP, 220V, 60 HZ, 1ph
Oil	AW32 or AW46
Breaker	30A
Weight	2,956 LBS
Dimension	209" L * 22" W * 34" H

DIMENSION

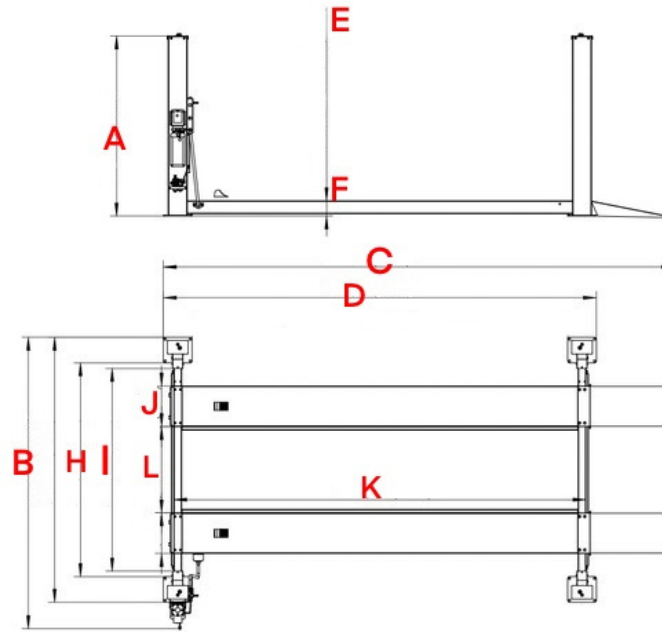

FEATURES

- Pneumatic safety lock release compact lift
- Max lifting height limiter switch to ensure the cylinders work within the stroke
- Skid proof diamond platform
- Dual safety device design: Second safety device will be automatically locked while primary safety locks are out of operation.
- Proofed by dynamic test with 115% of rated capacity and static test with 150% rated capacity
- Powder coating finish: Granite Gray (RAL 7026) + Reinorange (RAL 2004)

Standard Accessories (Included)

- 3 Pcs Oil Tray
- 1 pc Jack Tray
- Caster Kit (Set of 4)

Optional Add-On Accessories (Sold Separately)

- Rolling Bridge Jack
- Turntable Plate

View it on the website here:



Warranty

5 YEAR LIFTING STRUCTURE

3 YEAR HYDRAULIC

2 YEAR ELECTRIC