

## Safety - Installation - Operation - Maintenance

# Stratus Extra Wide Floor Plate 12,000 lbs Capacity Single Point Manual Release Auto Lift SAE-F12X

Model: F12X



Manual SAE-F12X— Aug 2024

### IMPORTANT NOTE:

1. Save these instructions!
2. This equipment should not be installed, operated or repaired without first reading the instructions. Failure to follow the instructions and safety can result in serious injury or death.
3. Electricity should be hooked up by a certified electrician.
4. Do NOT use equipment beyond its rated capacity.
5. Keep manual near lift for reference
6. By proceeding with installation and operation, you agree that you fully understand the contents of this manual and assume full responsibility for product use.
7. Only Operate this lift if it can be done so safely.

# Introduction

This manual is designed to help customers use Stratus F12X, 2 post lift. This is a floor plate lift with an open center that provides full under vehicle access.

This lift comes with a capacity of 12,000 LBS.

Stratus recommends keeping this manual within reach of the lift for anyone who is to use or service the machine. Frequently asked questions and Troubleshooting steps have been included within this manual. If you have any questions and/or issues which are not answered here, please contact us at **512-640-9896** or email [support@stratusautoequip.com](mailto:support@stratusautoequip.com)

# Symbols

Following are the symbols used in this manual:

 **DANGER** Calls attention to an immediate hazard that will result in injury or death.

 **WARNING** Calls attention to a hazard or unsafe practice that could result in injury or death.

 **CAUTION** Calls attention to a hazard or unsafe practice that could result in minor personal injury, product, or property damage.

**NOTICE** Calls attention to a situation that, if not avoided, could result in product or property damage.

 **Tip** Calls attention to information that can help you use your product better.

# Liability

Stratus Auto Equipment assumes no liability for damages resulting from:

- Use of the product for purposes other than those described in this manual.
- Modifications to the equipment without prior, written permission from Stratus Auto Equipment
- Injury or death caused by modifying, disabling, overriding, or removing safety features.
- Damage to the equipment from external influences.
- Incorrect or improper operation of the equipment.

## **Manual -F12X Stratus Extra Wide Floor Plate 12,000 lbs Capacity Single Point Manual Release Auto Lift SAE-F12X - Safety - Installation - Operation - Maintenance**

**Copyright** - Copyright © 2024 by Stratus Metals, Inc. dba Stratus Auto Equipment reserves all rights. Copies may be made of this document if you agree full attribution to Stratus Metals Inc. Changes and Copies for commercial purposes to this document are prohibited.

**Trademarks-** Stratus Auto Equipment and logo are registered trademarks of Stratus Metals, Inc. All other company, product, and service names are used for identification only. All trademarks and registered trademarks mentioned in this manual are the property of their respective owners.

**Limitations-** Whereas every effort has been made to ensure this manual has complete and accurate information; Product updates, revisions, and/or changes could have occurred since this manual was written and published. Stratus Auto Equipment reserves the right to change any information in this manual without incurring any obligation for equipment previously or subsequently sold. Stratus Auto Equipment is not responsible for typographical errors in this manual.

**Safety-** Your product was designed and manufactured with safety in mind. However, your safety also depends on proper training and thoughtful operation. Do not install, operate, maintain, or repair the unit without reading and understanding this manual and the labels on the unit; *do not use your Lift unless you can do so safely!*

**Owner Responsibility-** In order to ensure operator safety and maintain your product properly, it is the responsibility of the product owner to read and follow these instructions:

- Follow all setup, operation, and maintenance instructions.
- Make sure product setup and use conforms to all applicable local, state, and federal codes, rules, and regulations, such as state and federal OSHA regulations and electrical codes.
- Read and follow all safety instructions. Keep them readily available for operators.
- Make sure all operators are properly trained, know how to safely operate the unit, and are properly supervised.
- Do not operate the product until you are certain all parts are in place and operating correctly.
- Carefully inspect the product on a regular basis and perform all maintenance as specified.
- Service and maintain the unit only with approved replacement parts.
- Keep all instructions permanently with the product and make sure all labels are clean and visible.

Stratus Auto Equipment makes no promises, guarantees or assurances that our products meet any state, county, federal or international mandated permit, license, code, standard, certification, or any other mandate other than what is listed or shown on Stratus Auto Equipment's website. Not all of Stratus Auto Equipment lift models meet the standards as prescribed by ANSI/ALI ALCTV-(current edition) or ANSI/UL 201. Consult [www.autolift.org](http://www.autolift.org) for a complete list of lift models that meet ANSI/ALI ALCTV-(current edition) or ANSI/UL 201 or contact [support@stratusautoequip.com](mailto:support@stratusautoequip.com)

Buyer assumes full responsibility for any state, county, federal or international mandated permit, license, code, standard, certification, or any other mandate required related to the installation and/or operation of any Stratus Equipment. Stratus will not be responsible for any charges, fines, liens, or other levies imposed on the Buyer related to any special or regional structural, seismic or any other building code and/or codes such as the Uniform Building Code (UBC), International Building Code (IBC), or any other state, county, federal or international mandated permit, license, code, standard, certification, or other mandate, law, rule, regulation or directive by any other agency, government, administrations, or corporations whether state, county, federal, or international mandated.

## Unit Information

Be sure to document the Model Number, Serial Number, and Date of Manufacture from the label on your unit below. This information is required for part or warranty issues.



**STRATUS**<sup>®</sup>  
auto equipment

STRATUS AUTO EQUIPMENT  
[www.stratusautoequip.com](http://www.stratusautoequip.com)  
[sales@stratusautoequip.com](mailto:sales@stratusautoequip.com)  
Tel: 512-640-9896



MODEL:

DATE:

SERIAL NO.

Lifting Capacity:

lbs

Rated Voltage:

V

Lifting Height:

in

Rated Frequency:

Hz

Min Height:

in

Phase:

Ph

Platform Length:

in

Net Weight:

lbs

# Index

<b>1-Equipment Description</b>	<b>3</b>
1.1-Description	3
1.2-Technical Specifications	3
1.3-Installation requirement	5
<b>2-Specifications of concrete</b>	<b>6</b>
<b>3-Installation steps</b>	<b>7</b>
<b>4-Check Before Start</b>	<b>16</b>
4.1-Mechanical Installation Check	16
4.2-Electrical Hook Up Check	16
4.3-Hydraulic System Testing	17
4.4-Load Test	17
<b>5-Operation and use</b>	<b>18</b>
5.1-Operation	18
5.2-Raising/ Lifting	18
5.3-Stopping	18
5.4-Lowering	18
<b>6-Safety</b>	<b>18</b>
6.1-Important reminder	18
6.2-Vehicle position	19
6.3-Risk of Vehicle falling off from the lift	19
<b>7-Maintenance</b>	<b>20</b>
<b>8-Troubleshooting Guide</b>	<b>21</b>
<b>9-Structure and Parts List</b>	<b>22</b>
9.1-Main column assembly	22
9.2- Sub-column assembly	23
9.3-Carriage assembly	24
9.4-Hydraulic cylinder assembly	25
9.5-Main column safety lock assembly	26
9.6-Secondary column safety lock assembly	27
9.7-Three-section arm assembly	27
Special Notes	28
Important Safety Instructions	29

### 1-Equipment Description 1.1-Description

This 2 Post Floor Plate Lift is an advanced piece of car & truck maintenance equipment, mainly used for automotive repair and maintenance.

### 1.2-Technical Specifications

Model	SAE-F12X
Lift Capacity	5500KG/12000lbs
Overall Height	3117mm/122 3/4"
Overall Width	3940mm/155 1/8"
Maximum Lifting Height	1900mm/74 13/16"
Minimum Height	125mm/4 15/16"
Lifting Time	About 60 sec.
Outside Column to Outside Column Width	3742mm/147 5/16"
Inside Column Width	3300mm/129 15/16"
Drive Through	2949mm/116 1/8"
Column Thickness of Steel	6mm/0.236"
Carriage Thickness of Steel	6mm/0.236"
Arms Thickness of Steel	8mm/0.315"
Equalized Cable Diameter	9mm/0.354"
Voltage	220V
Power	3.0Kw/4Hp
Breaker	30A
Hydraulic Oil	3-5 Gallons AW32/AW46
Equipment Weight	1980LBS

Installation (See Fig 1)

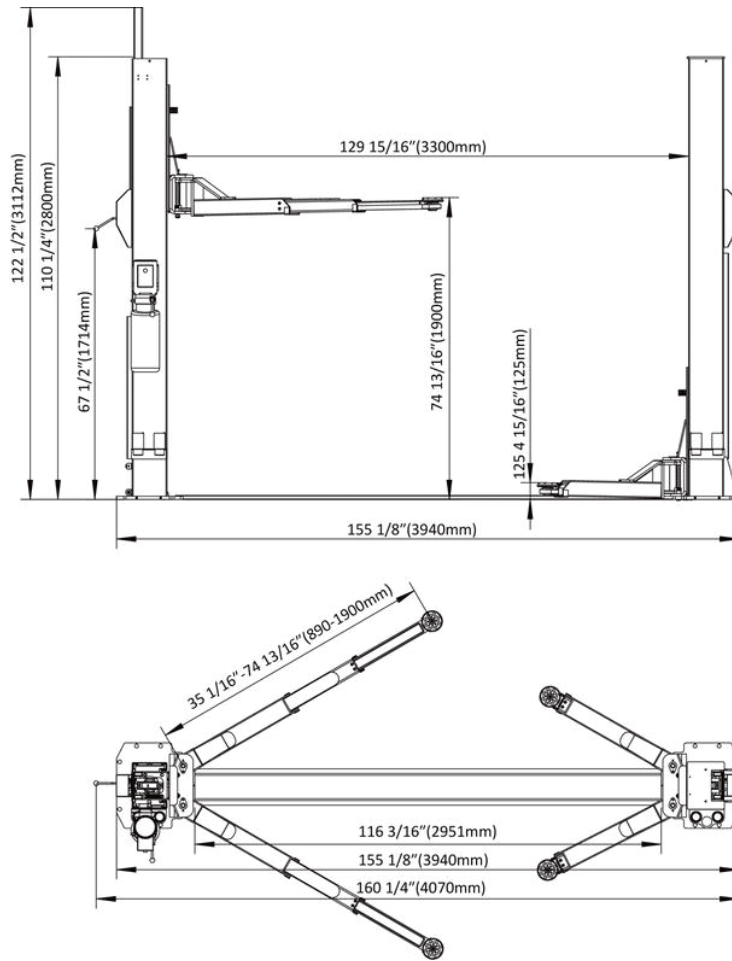

FIG 1

Features (See Fig 2)

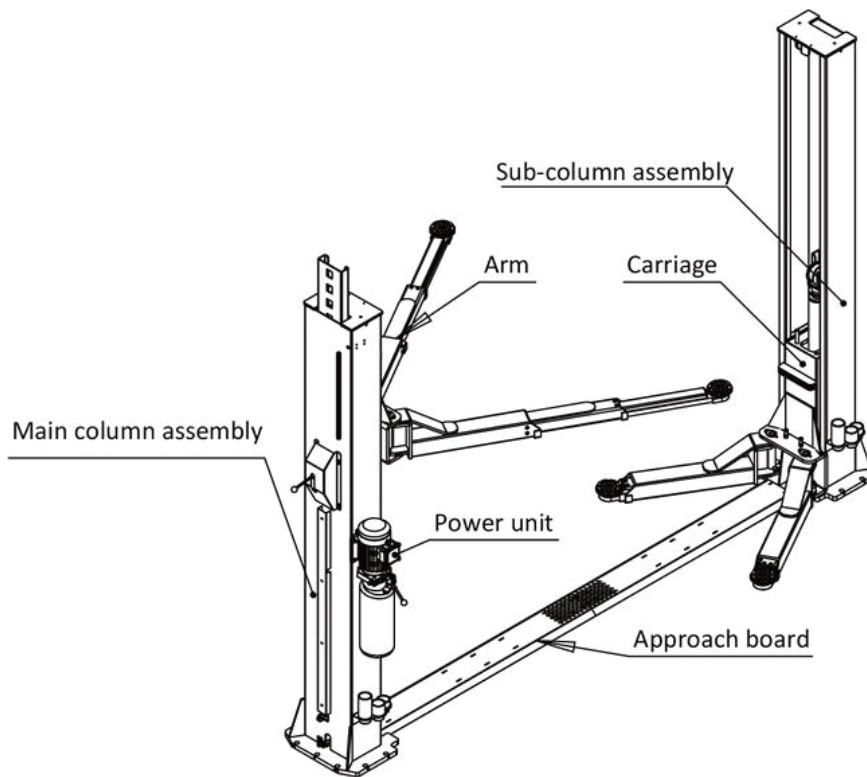













FIG 2



### 1.3-Installation requirement

#### Tools required

Name	Picture
Rotary hammer drill( $\Phi$ 19)	
carpenter's chalk	
Hammer	
Screwdriver Sets	
Level bar	
Tap measure	
English spanner(12")	
Pliers	
Ratchet spanner with socket(28#)	
Socket head wrench(3#,5#,8#)	
Lock wrench	
Wrench set(10#,13#,14#,15#,17#,19,24#,27#,30#)	

**2-Specifications of concrete ( See Fig 3 )** Specifications of concrete must be adhered to the specification as following.

Failure to do so may result in lift and/or vehicle falling.

- ◇ Concrete must be a minimum thickness of 200mm minimum and without reinforcing steel bars, and must be completely dry before lift installation
- ◇ Concrete must be in good condition and must be of test strength 3500psi(245kg/cm<sup>2</sup>)minimum.
- ◇ Floor must be level with no cracks or holes.

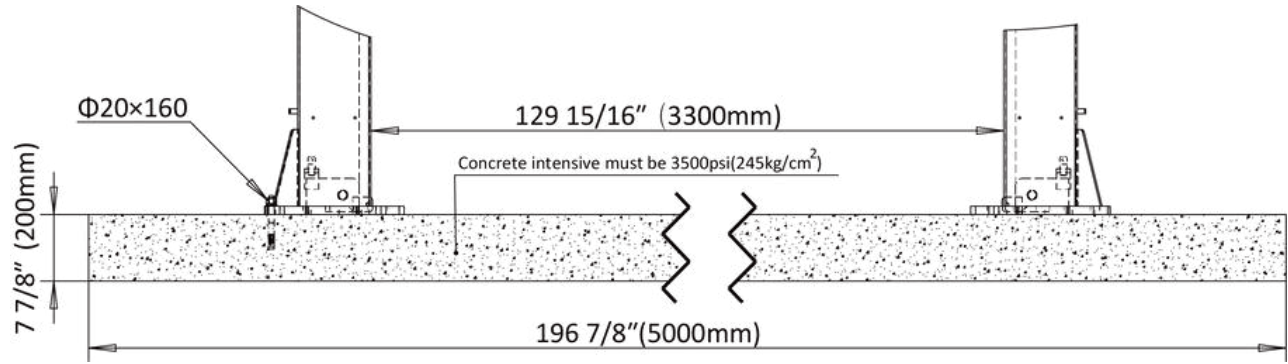

**FIG 3**

**Steps of installation**

- ◇ Location of installation

Check and insure the installation location( concrete, layout, space size etc.) is suitable for lift installation.

- ◇ Use a carpenter's chalk line to establish installation layout of baseplate( See Fig4).

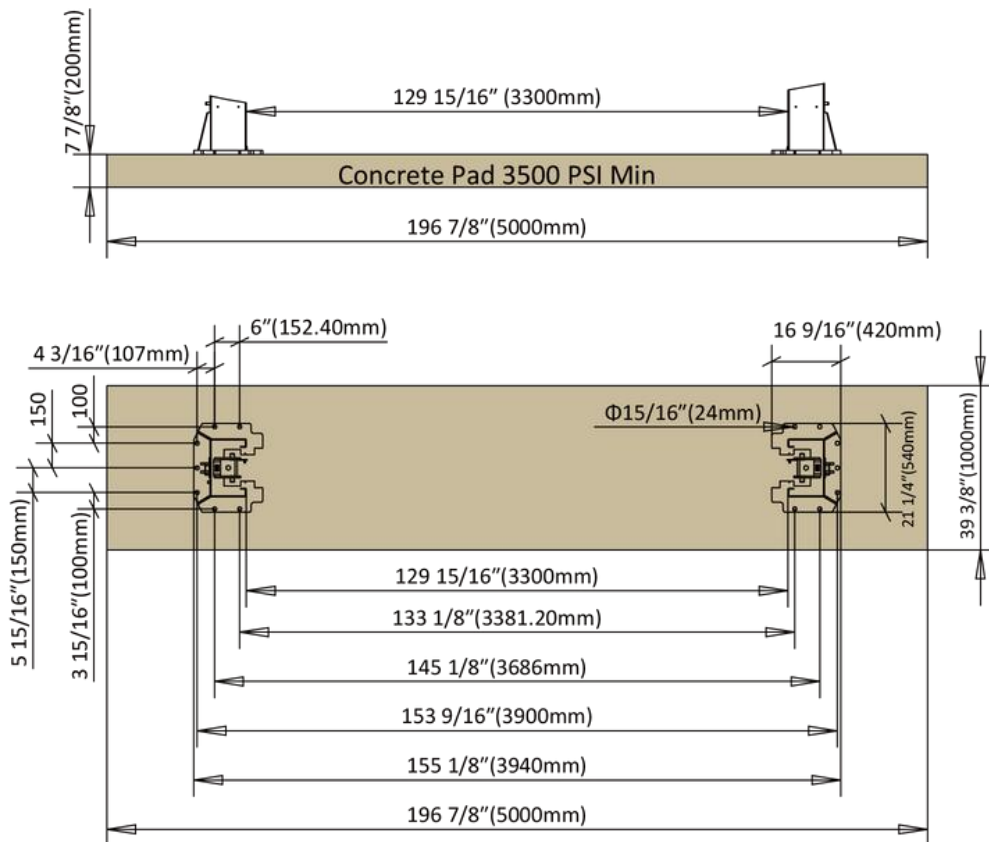

**FIG 4**

### 3-Installation steps

#### Step 1:Check the parts before assembly

Packaged lift and hydraulic power unit( See Fig 5)

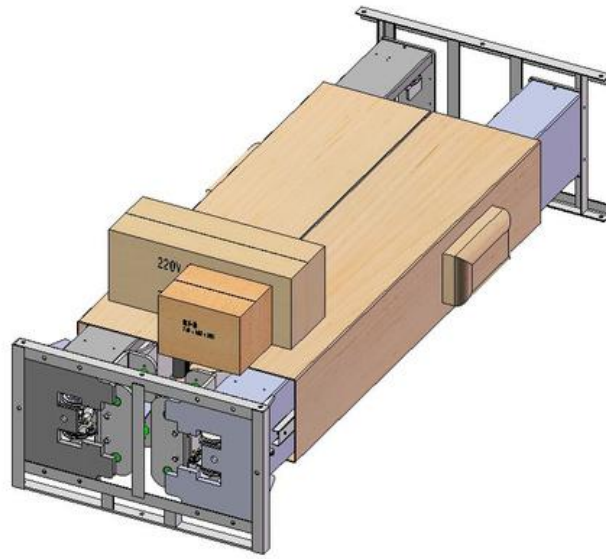

FIG 5

Step 2:Move aside the parts and check the parts according to the shipment parts list (See Fig 6).

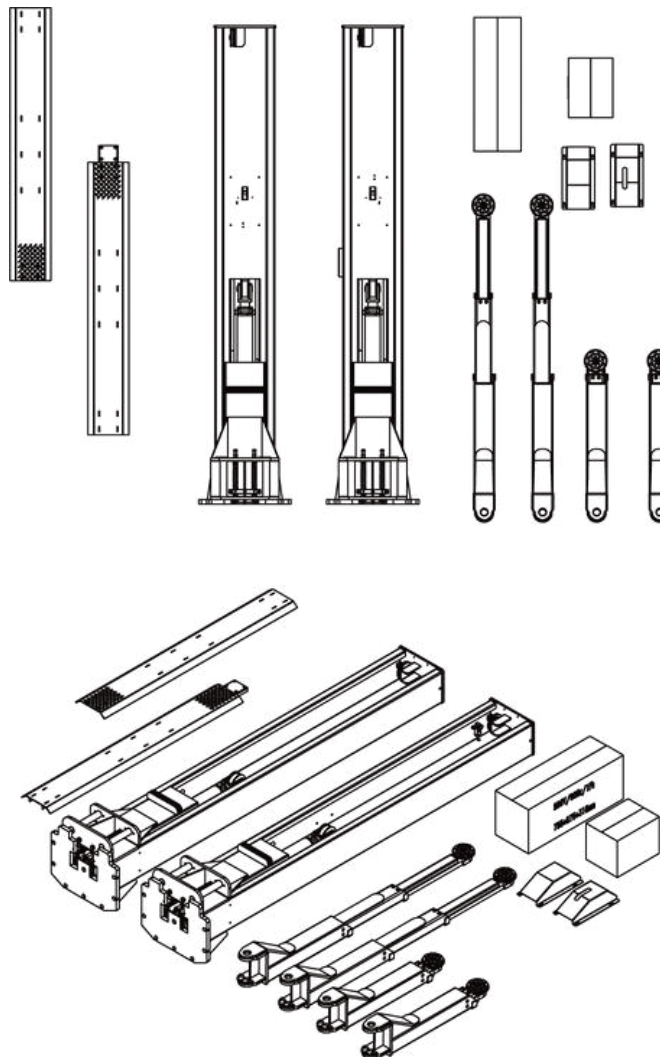























FIG 6

**Step 3: Spare parts in the accessories box.**

NO.	Name	Photo	Parameter	Qty.
1	Arm Pivot Pin		Φ40×250L	4
2	Pivot Retaining Screw		Countersunk Hexagon Screw M10×15L	4
3	Arm Pivot Washer		Φ70mm	4
4	Truck Adaptor (NOT STACKABLE. FOR SINGLE USE ONLY.)		Φ60×100L	4
5	Adapter Rack			2
6	Truck Adapter Set Screw		Hexagon socket screws M8×10L	4
7	Door Bumper			2
8	Bumper Screw		Hexagon socket screws M8×30	4
9	Power Unit Mounting Bracket			1
10	Power Unit Mounting Screws		Hexagon socket screws M10×16L	Each 2
11	Motor Mount Screws		Hexagon Screw M8×25L	Each 4
12	Lock Release Lever		M10	Each 1
13	Safety lock release cable			1
14	Safety Cable Clamp		M3	2
15	Expansion Anchors		M20×160L	14
16	Plastic Shims			15
17	Zip-Tie			30
18	Upper Limit Switch			1
19	Limit Switch Mounting Screws		Phillips round head screws M5× 10L	2
20	Lock Cable Pulleys			6
21	User's manual			1

**Step 4: Install anchor bolts**

Position the columns on the installation layout of baseplate. Install the anchor bolts. Check the columns plumbness with level bar, and adjusting with the shims if the columns are not vertical. Do not tighten the anchor bolts (See Fig 7).

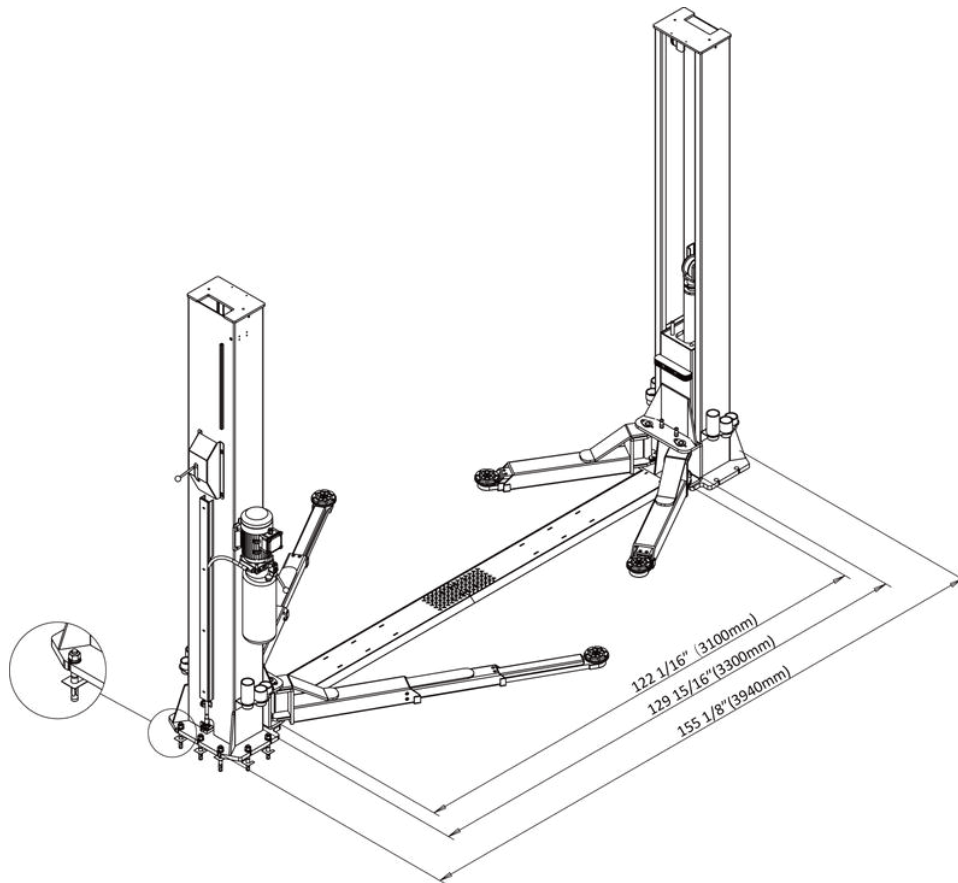

FIG 7

**Install Anchor Bolts (Fig 8)**

1. Adjust the distance between 2 columns as required dimensions (Fig 8).
2. Adjust the opening direction of the two columns in a straight line (visible).
3. Install Anchor Bolts (Suggest to use 3/4" Drill).

Note: Don't Fasten/Tighten Nuts now in case any adjustment needed.

4. Adjust the verticality of the columns (visible) and use U-shape washer (come with package) if necessary.

5. Tighten anchor bolts nuts in diagonal order (Foot Pounds of Torque:90+, suggest to use hand wrench to tighten nuts).

Note: Anchor bolts driven into the ground at least 150mm.(See Fig 8)

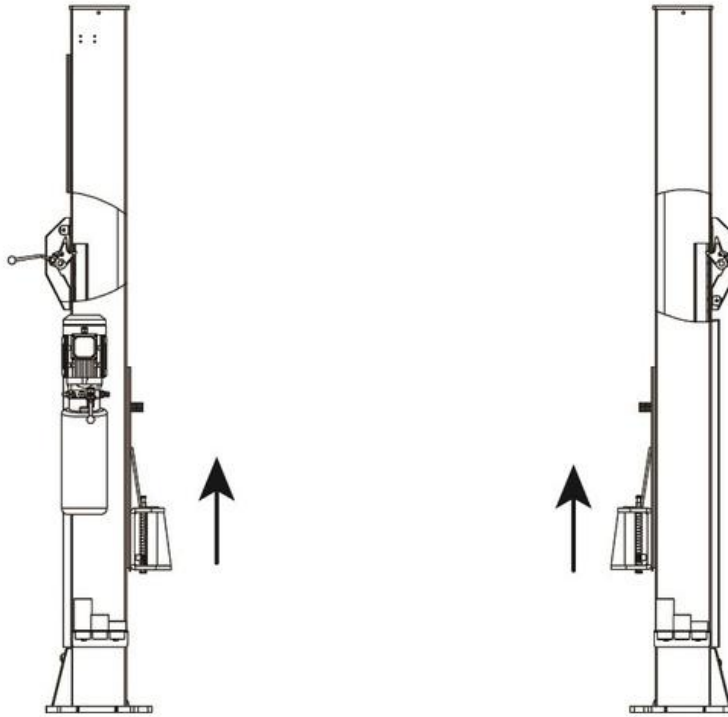

FIG 8

**Step 5: Adjust Carriage**

Raise the carriage to the 1st locking position located at the bottom of the column (Fig 9).

**Note: You can hear 'click' once locked.**



**Fig 9**

**Step 6: Install Equalized Cables (2 Cables in total)**

Red & Blue color in this Fig are showing how to route the 2 cables (Fig 10).

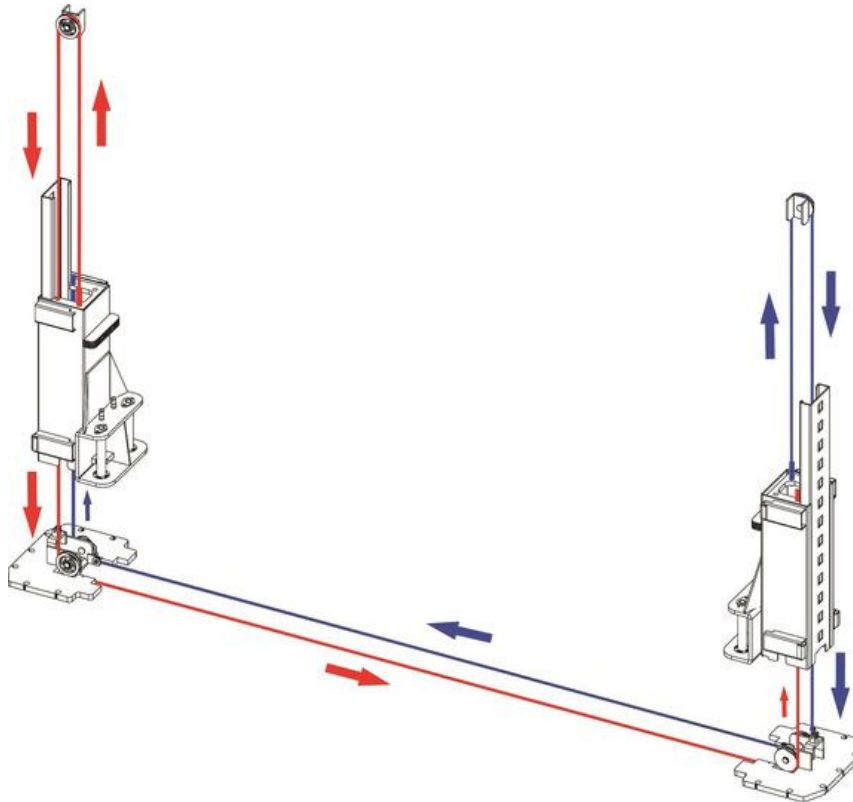

**Fig 10**

**Step 7: Install Hydraulic Hose (2 hose in total)**

Connect the longer hose in between the 2 cylinders, connect the short hose in between the cylinder and the power unit. Please tighten the nuts with hand to avoid thread damage, then use hand wrench to fasten completely. ( Fig 11)

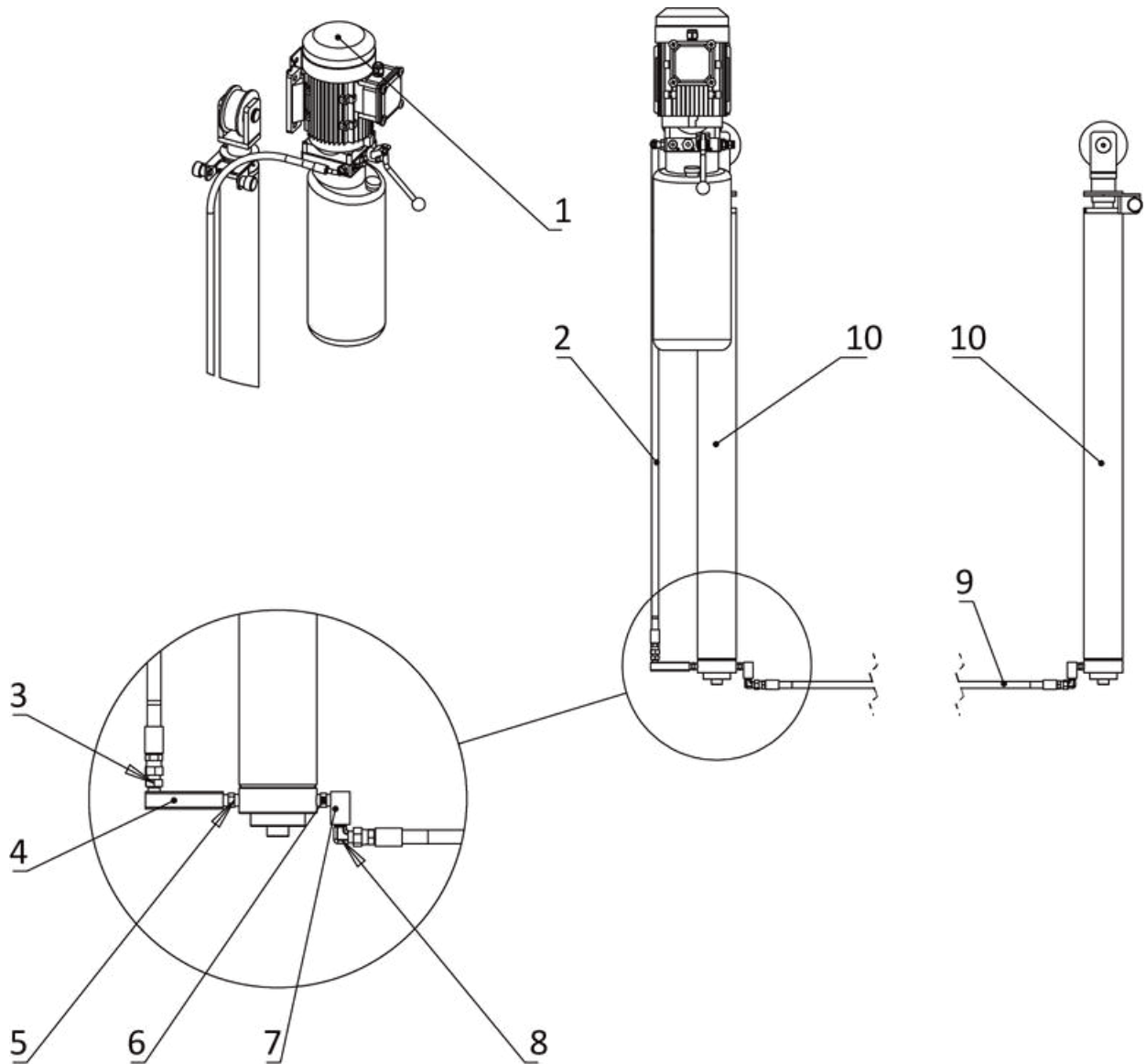

No.	Name	Qty.	No.	Name	Qty.
1	Power unit	1	6	Connector 2	1
2	Hose 1	1	7	Connect square steel 2	1
3	Connector 1	1	8	Right angle connector	1
4	Connect square steel 1	1	9	Hose 2	1
5	Connector 2	1	10	Hydraulic cylinder	2

Fig 11

**Step 8: Install Safety Lock Release Cable** 1.The safety lock has been pre-installed. 2.Install safety lock release cable to connect the safety lock on the main column and vice column. (Fig 12) 3.Install safety lock cover. **NOTE: Press the single point lock release lever on the main column to check if this lever can release the mechanisms in both columns at the same time. Adjust the safety lock release cable adjustment screw if necessary until the lever can release the mechanisms in both columns at the same time.**

Main column

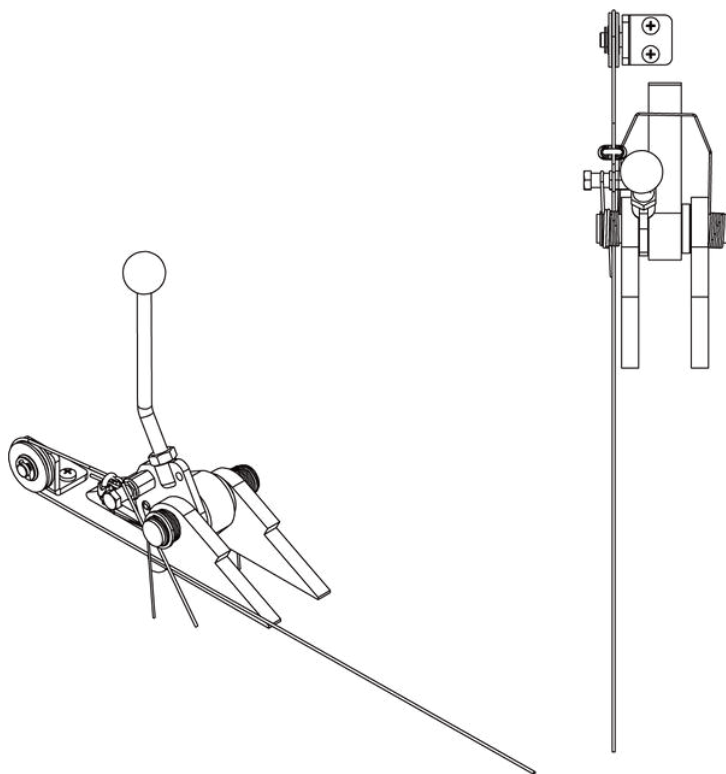

Vice column

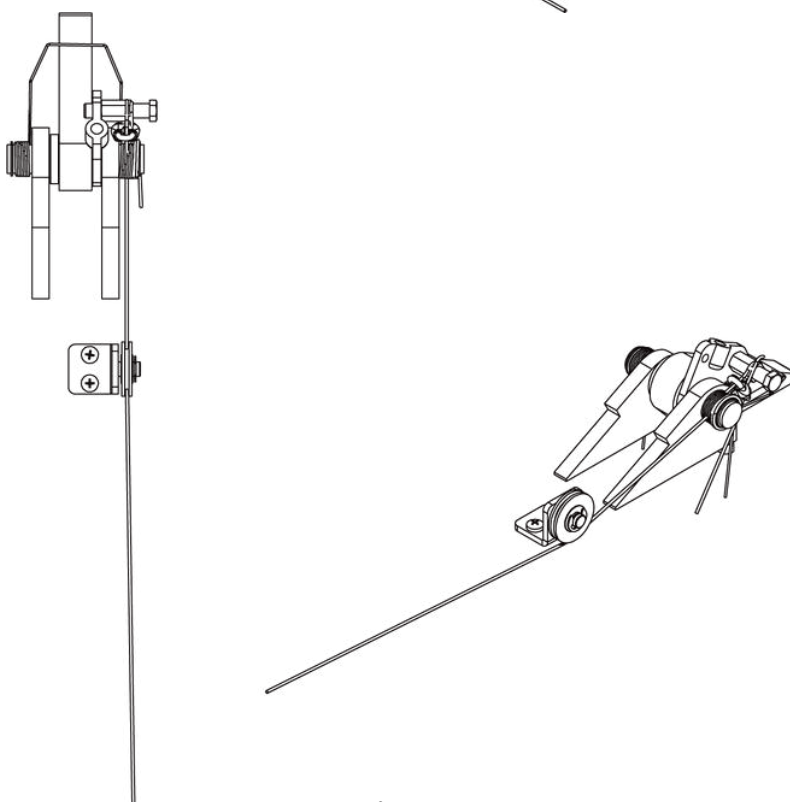
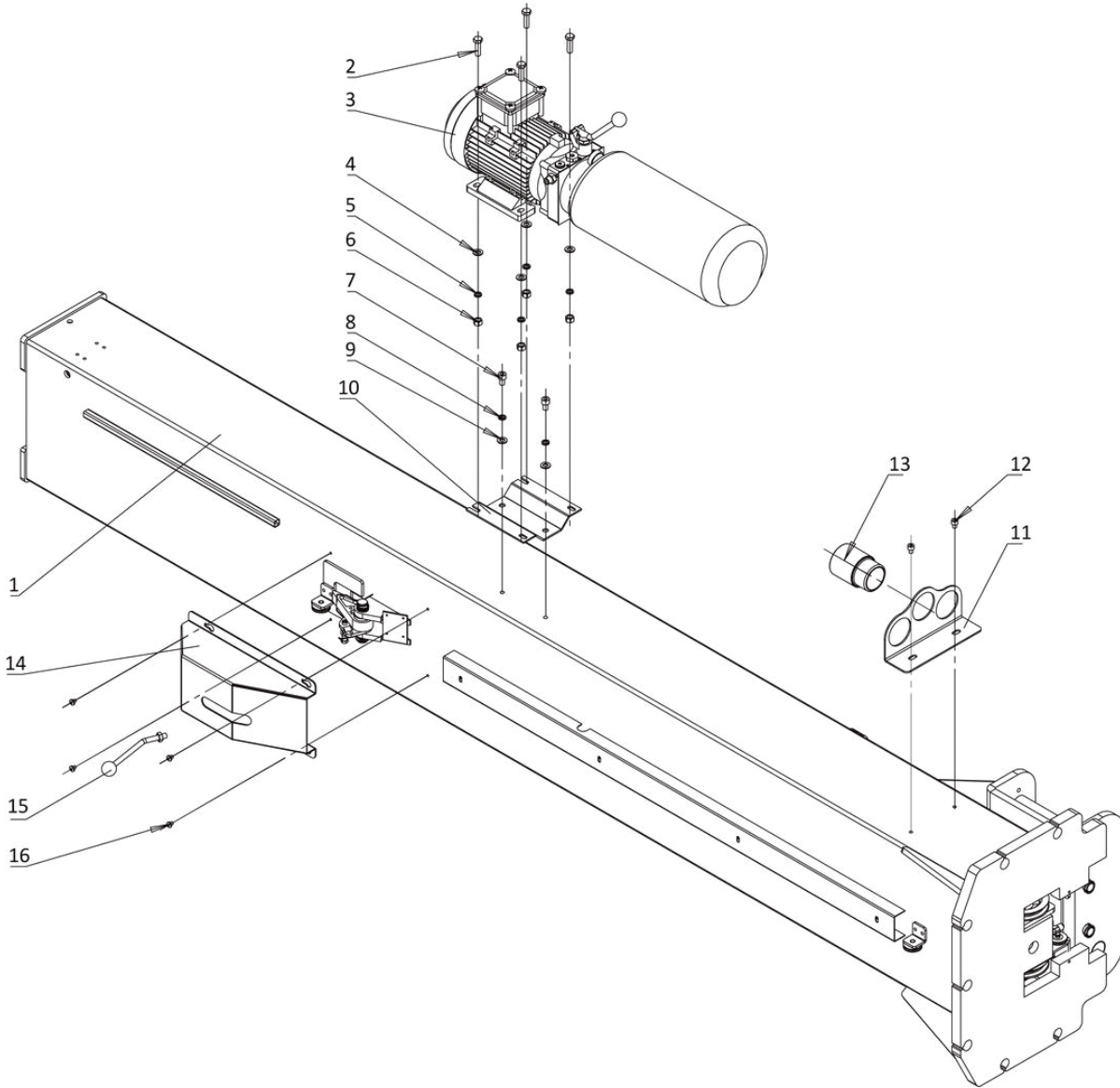

Fig 12



**Step 9: Install Power Unit** Install power unit & motor mounting plate on the main column with screws. Install Power unit, truck adapter holder and motor mounting plate. (Fig 13).

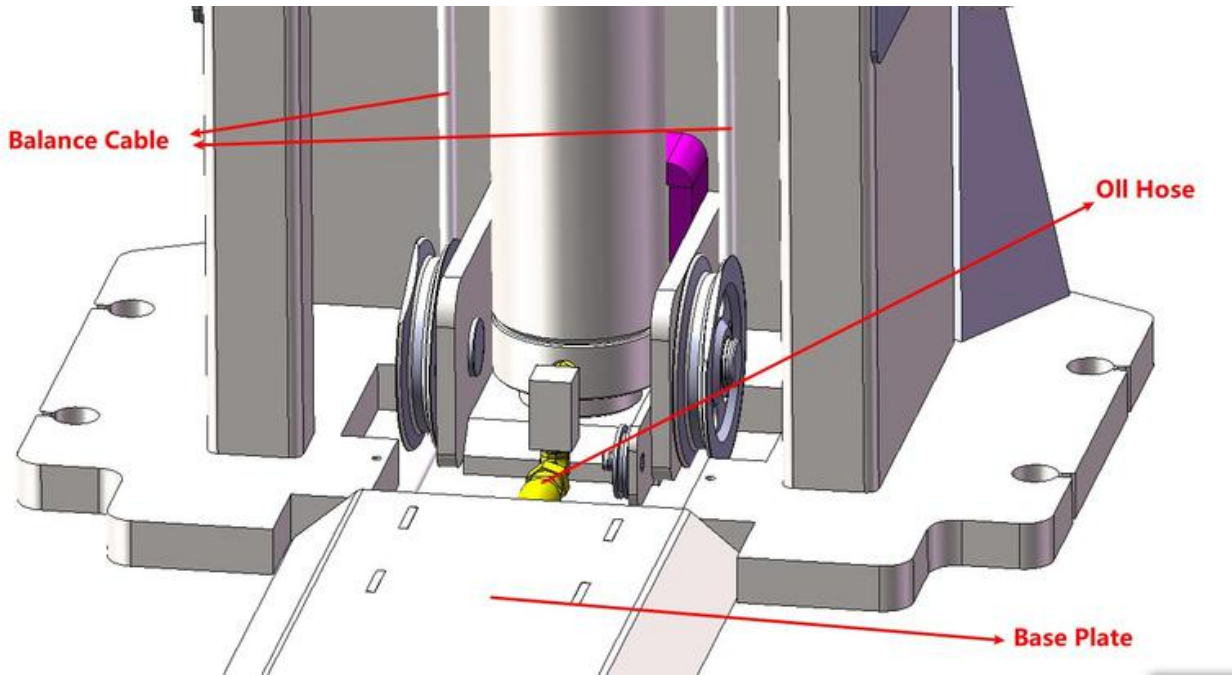

**Fig 13**

No.	Name	Qty.	No.	Name	Qty.
1	Main column assembly	1	9	Flat pad $\Phi 10$	2
2	Hexagon screw M8×25	4	10	Power unit backpack	1
3	Power unit	1	11	Heightening bracket	1
4	Flat pad $\Phi 8$	4	12	Socket head cap screws M8×10	2
5	Spring cushion $\Phi 8$	4	13	Increase the set	1
6	Hex nuts M8	4	14	Safety lock cover (Opening)	1
7	Socket head cap screws M10×16	2	15	Unlock lever	1
8	Spring cushion $\Phi 10$	2	16	Phillips round head screws M6×8	4

**Step 10: Safety Lock Release Cable & Hose & Limiter Switch Wire Protection cover.**

**1. Safety Lock Release Cable & Hose & Top Limiter Switch Wire Position (Fig 14).**



**Fig 14**

**2. Install protection cover (Fig 15)**

**NOTE:** The protection cover on the extension column for safety lock release cable & hose & top limiter switch you need to install the protection cover on column.

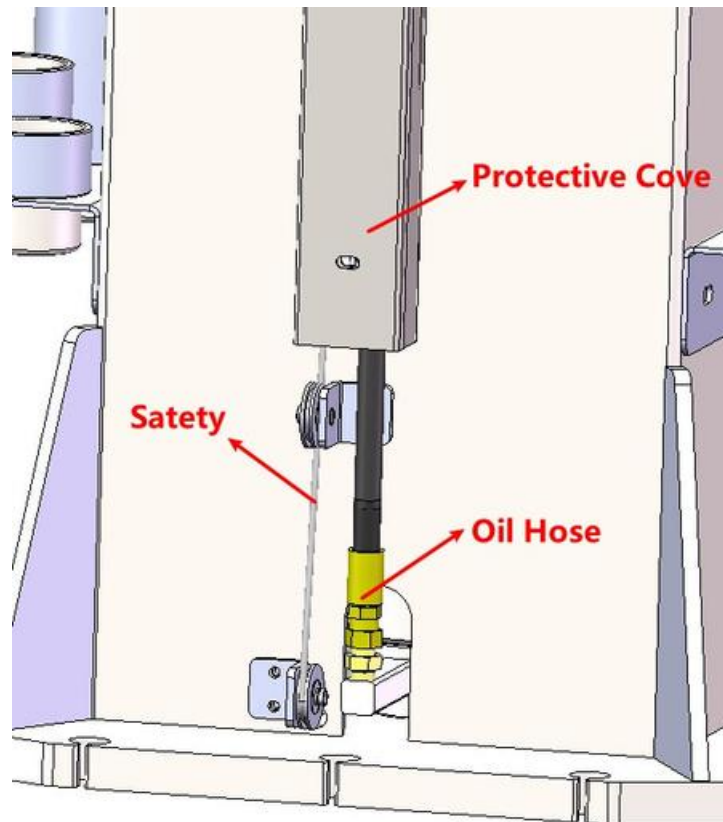

**Fig 15**

**Step 11: Install Base Plate (Fig 16)**

Place the Baseplate inside the columns slots.( No screws needed).

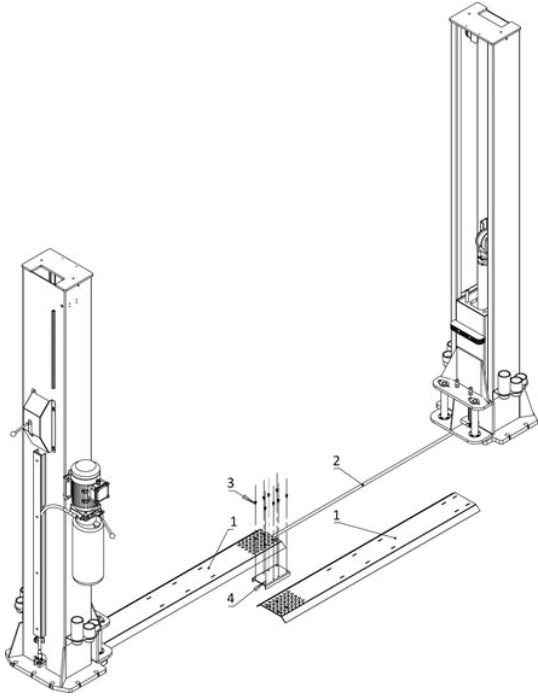

No.	Name	Qty.
1	Approach board welding	2
2	Hose 2	1
3	Phillips round head screws M8×10	8
4	Approach board connecting board	1

**Step12: Install lifting arms. (See Fig 17)**

Connect the lifting arm and the carriage. The arm pin shafts must be greased at the installation Ensure the arm lock can engage and release effectively. .

**Attention: Install Lifting arms and fix feet protection bars ONLY after the complete assembly has been erected and anchored.**

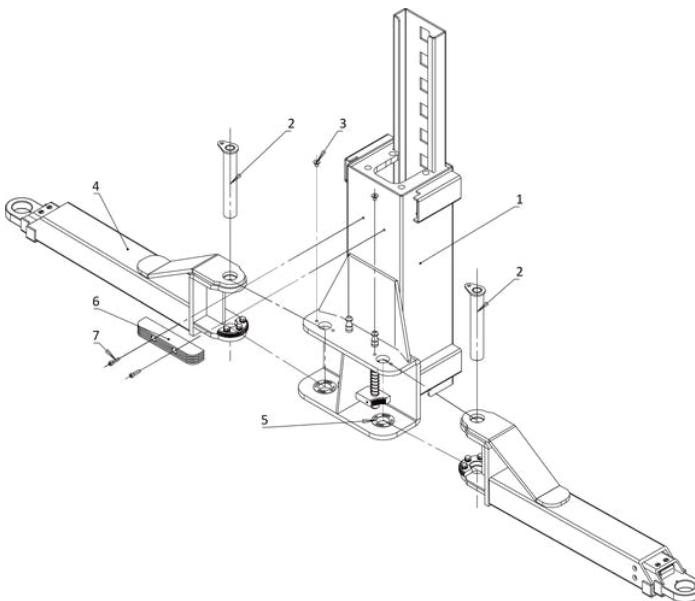

No.	Name	Qty.
1	Carriage welding	1
2	Arm shaft	2
3	Flat head hexagon socket screw M10×15	2
4	Three-section support arm	2
5	Arm washer	2
6	Anti-collision tape	1
7	Socket head cap screws M8×30	2

#### 4-Check Before Start

##### 4.1-Mechanical Installation Check

4.1.1-Check anchor bolts, nuts, fittings and etc have been installed properly.

4.1.2-Check if all moving parts move freely.

4.1.3-Make sure inside of the columns is clean and no other objects.

4.1.4-Supply grease between slide blocks and columns, cables and pulleys.

4.1.5-Check if the arm lock is locked while raising processing, and adjust lock if necessary.

Note: Loose the screw to adjust when necessary .

##### 4.2-Electrical Hook Up Check

Make sure all wiring are same as below circuit diagram (Fig 18).

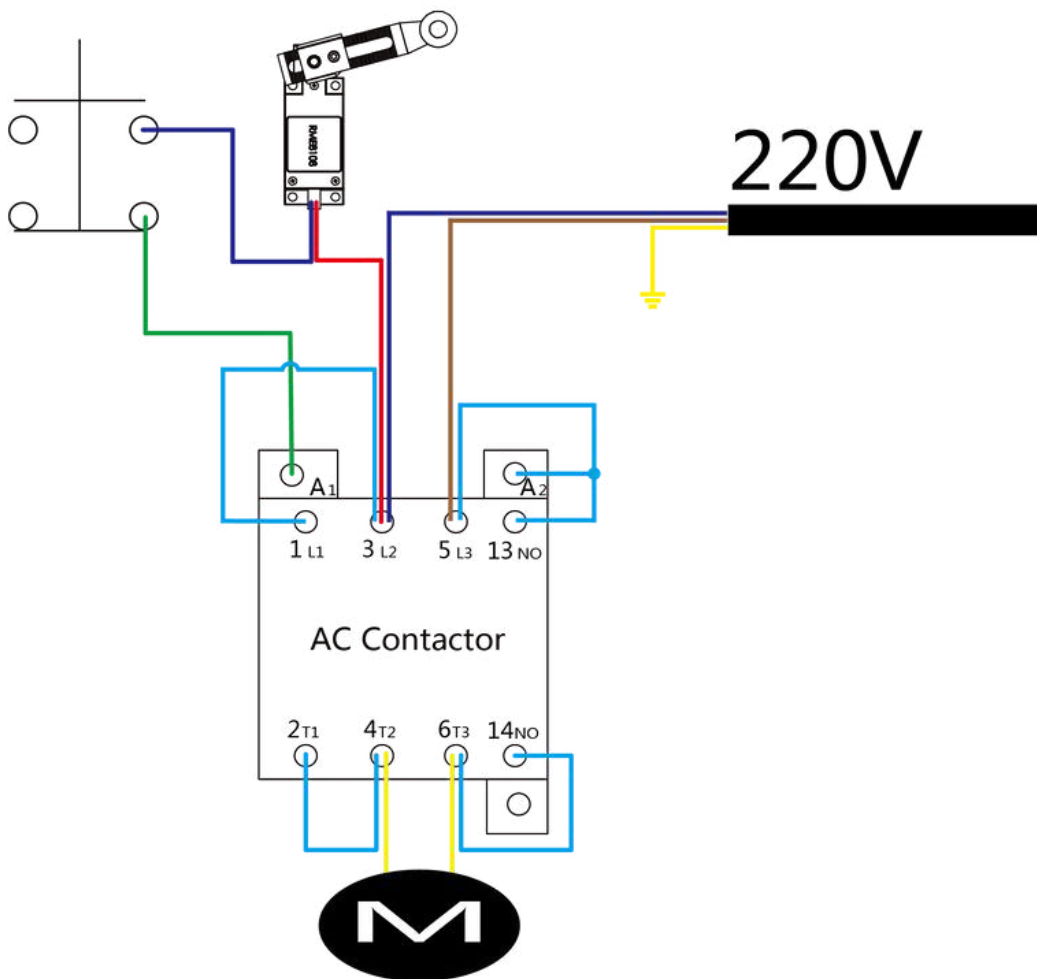

Fig 18 Power Unit Wiring Diagram ( Voltage:220V)

Attention: electrical system connection must be done by licensed electrician.

**Warning: When installing the power cord for the first time, remove the test cable (short wire) from the motor and replace it with a cable (wire) less than #12 gauge. The time interval between motor starts is at least more than 2 seconds. Otherwise the motor or AC contactor may be burnt out.**

Suggest to use min 30A breaker (not higher than the wire load).

### 4.3-Hydraulic System Testing

4.3.1- Add about 2.5 gallons of hydraulic oil to the hydraulic fluid reservoir, AW32 during winter time (cold weather), and AW46 during summer time (hot weather).

4.3.2-Make sure there is no oil leak.

4.3.3-Repeatedly raise and lower the lift to bleed trapped air from the cylinders.

4.3.4-Power unit testing (Fig 21).

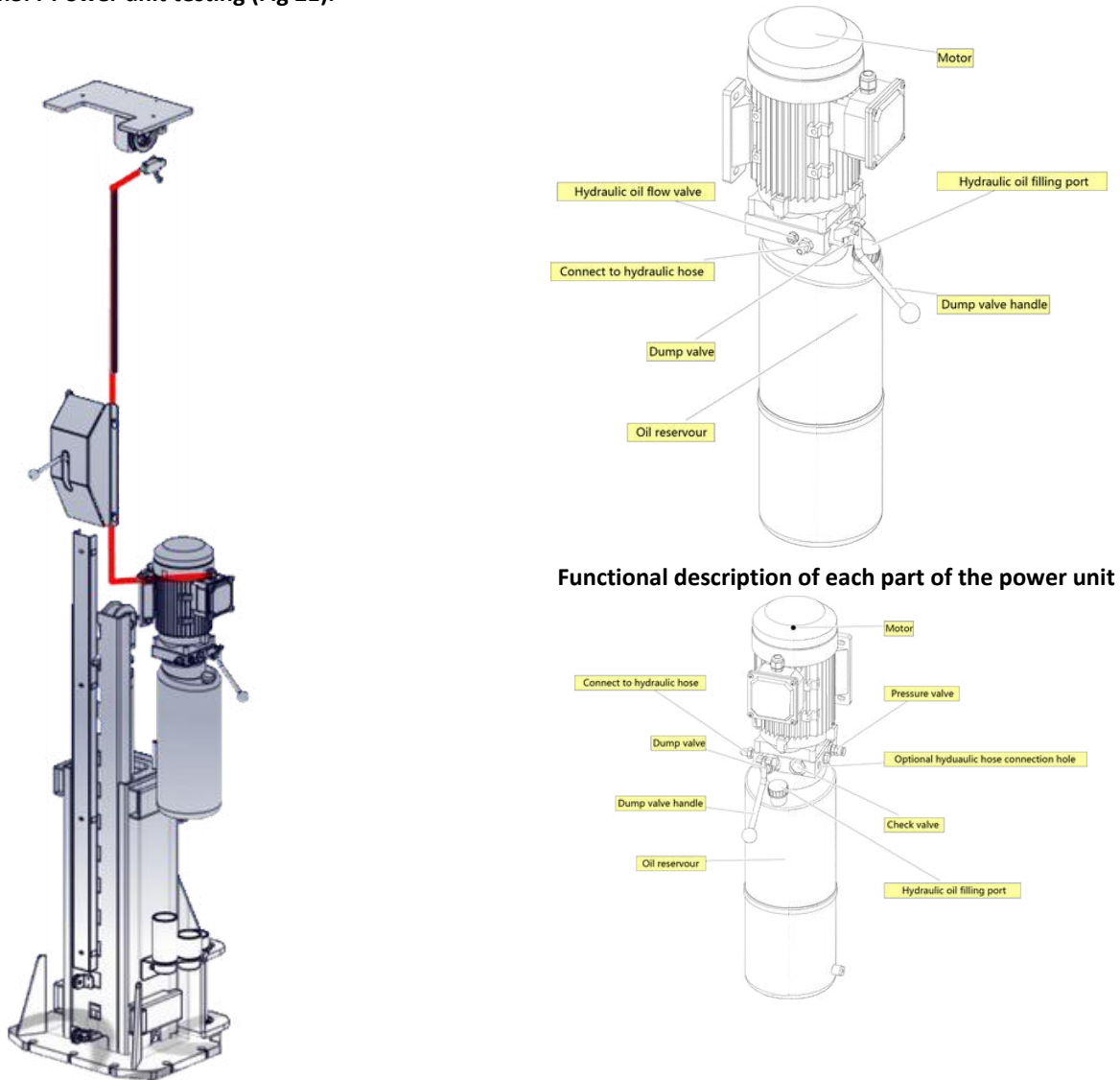

Functional description of each part of the power unit

Fig 21 Power Unit Diagram

### **\*\*Important Information\*\***

**Pressure Valve:** Clockwise adjustment increases pressure to make the power unit to have more power , counterclockwise adjustment decreases pressure to make the power unit to have less power.

**Hydraulic Fluid Flow Valve:** Clockwise adjustment to speed up, counterclockwise adjustment to slow down.

### 4.4-Load Test

Before testing, check anchor bolts to make sure they are completely tightened, and also make sure 2 carriage on both sides are at the same level (height difference should be less than 10mm/0.39"). Adjust the cable nut on the shorter carriage to make sure 2 carriage height at the same level and the 2 cables are similar tension.

## 5-Operation and Use

### 5.1-Operation

Place the lifting arm at the support point specified by the vehicle and adjust the rubber tray to the same height.

Check the position of the rubber tray under the vehicle chassis before each single raising or when vehicle is lowered to the ground and need to raise again.

### 5.2-Raising/ Lifting

Press the power switch until the vehicle reaches desired height. When the vehicle is raised, the safety lock automatically engaged.

During raising/lifting, whether the arm lock has been locked, it can be visually checked when it is raised to a certain height (stop and check).

**\*Danger\*:** Unlocked arms can cause vehicle fall off from the lift.

### 5.3-Stopping

After raising to desired height, press the lower lever and the lift will automatically lower to a safe position, the safety lock will be engaged and the lift will be locked.

### 5.4-Lowering

The safety lock must be released before lowering.

1. Press the power switch to raise the car by approximately 30mm/1.2".
2. Pull the safety lock release cables on both sides to unlock.
3. Press the lower lever to start lowering process, the arm lock will be automatically released and allow the arm rotating when the vehicle is completely lowered to the ground.

## 6-Safety

Please read this manual carefully as it contains important safety information that the operators need to know.

**\*WARNING\*:** The design and construction of this lift is only suitable for lifting whole vehicle. All other uses are unauthorized, this lift CAN NOT be used to : wash vehicles, build lifting platforms, lifting personnel, use as cargo lifts and use as lifting partial of the vehicles.

### 6.1-Important Reminder: Personal and Equipment Safety

6.1.1-During vehicle lifting process, operators should be at a safe position/area.

6.1.2.-Turn off the vehicle engine and manual brake on.

6.1.3-Load vehicle correctly (Fig 22).

6.1.4.-The vehicle CAN NOT exceed the rated lifting capacity and required size.

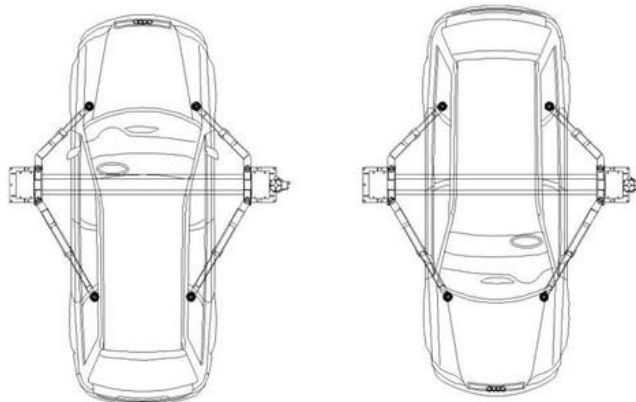

Fig 22

## 6.2-Vehicle Position

Once the vehicle is raised, vehicle **CAN NOT** be moved backwards or forwards as it may cause falling.

**\*WARNING\*:** Do not attempt to move the vehicle while it is parked on the lift.

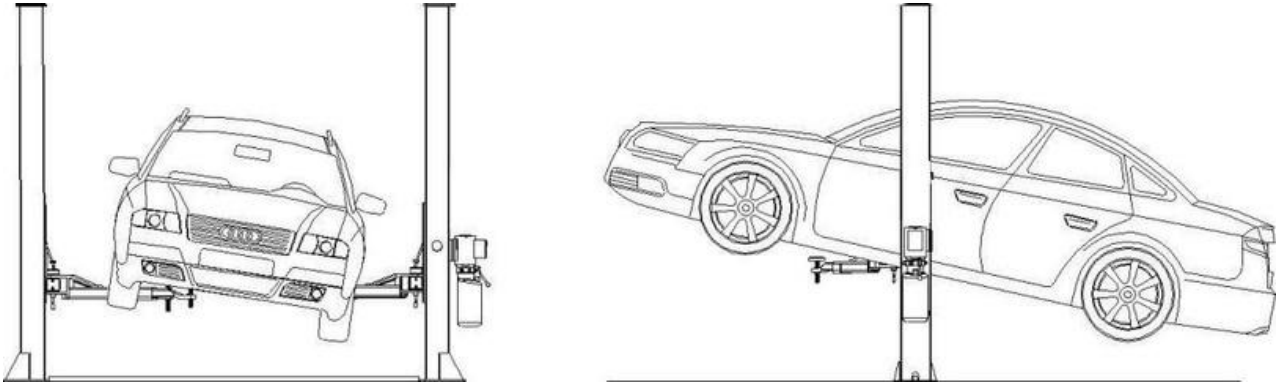

Fig 23

## 6.3-Risk of Vehicle falling off from the lift

Note that when positioning the vehicle on the lift, incorrect center of gravity of the vehicle can cause the vehicle falling off from the lift (Fig 23).

**Important Note:** Make sure that the front and rear of the vehicle need to be balanced and the cables on both sides also need to be balanced. Do not board/step on the vehicle or the lift when the lift is raised.

Below actions may cause the vehicle fall off from the lift (Fig 24)

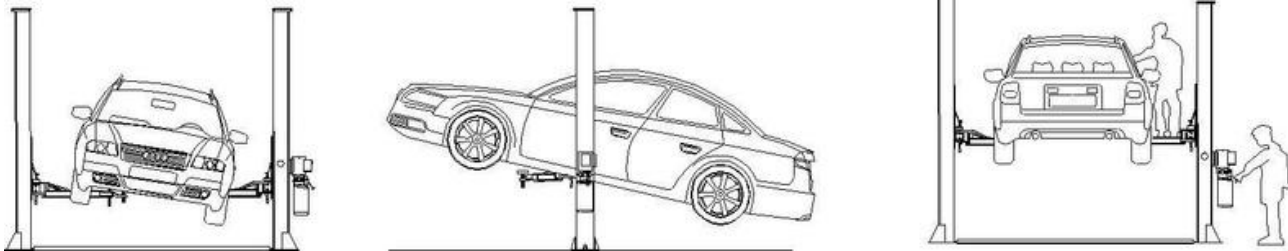

Fig 24 DO NOT do

## **7-Maintenance 7.1-Every Month Hydraulic System**

**7.1.1-Check hydraulic oil level, fill hydraulic oil if necessary.**

**7.1.2-Check the pump, hose and cylinder and see if there is hydraulic oil leaking.**

## **7.2-Every 3 Month - Safety Maintenance**

**7.2.1- Check the condition of the safety lock and the wear of the stop block.**

**7.2.2- Check the anchor bolts, tighten nuts if necessary.**

**7.2.3- Check if any nuts are loose, tighten nuts if necessary.**

**7.2.4- Check if the arm locking system is working properly.**

**7.2.5- Lubricate/grease all moving parts.**

**7.2.6- Check if the arm locking system is working properly.**

**7.2.7- Check if the 2 carriage on both sides are at the same level.**

## **7.3-Every 6 Month - Hydraulic Pump**

**7.3.1-Check the condition and aging of the hydraulic fluid. Unqualified hydraulic fluid is the main reason to cause valve failure and reduces the life of the gear pump.**

**7.3.2-Check the noise variation of the motor and gear pump while normal operating.**

## **7.4-Every 12 Month**

**7.4.1- Visually inspect all structural and mechanical parts to make sure there is no abnormalities have occurred.**

**7.4.2- Check and see if there is anything wrong with the motor, wiring ,top limiter switch and circuit breaker.**

## **7.5-Regular Lubrication**

**Use high quality grease to regularly lubricate all moving parts of this lift.**



## 8-Troubleshooting Guide

### Troubleshooting Guide

Malfunction	Possible reason	Solution
The motor does not work	Check the air switch.	Turn off or replace the air switch.
	Check if the voltage is correct.	Use correct power supply.
	The motor burned.	Replace the motor.
	Start switch burned.	Replace the start switch.
	Top limiter switch burned.	Replace the top limiter switch.
	AC contactor burned.	Replace the AC contactor.
The motor works but can't lift	Pressure valve pressure is too small.	Clockwise adjust the pressure valve( fine adjustment).
	Pump station takes in air.	Unscrew check valve on the power unit, and then start the motor until hydraulic oil flows out from the check valve.
	Hydraulic oil suction hose is detached or broken. Insufficient hydraulic oil.	Install/replace the suction hose.
	Safety lock engaged.	Fill more hydraulic oil.
Does not lowering		Slightly raise the device and then pull the safety lock release cable.
	Other object inside the columns stops the carriage.	Check and remove the objects.
	The flow valve needs to be adjusted.	Counterclockwise adjust the flow valve (fine adjustment).
Self-Lowering	Dump valve failure.	Replace the dump valve.
	Hydraulic oil leaks.	Check and repair.
	The valve body of the power unit has holes.	Replace the valve body holes.
Raise without load, but doesn't raise with load	The voltage is too low.	Install the voltage stabilizer.
	Objects in the dump valve.	Remove objects from the dump valve.
	The pressure valve pressure is too small.	Increase pressure properly (fine adjust the pressure valve).
	Overload.	This operation is prohibited.
Lifting is not leveled	The cables are not balanced.	Balance cables by adjusting cables length.
Loud motor noise	After raising to the highest point, the motor is still working and the top limiter switch is disabled.	Replace the top limiter switch.
	Hydraulic oil pollution.	Replace the hydraulic oil.
	Overload.	This operation is prohibited.

## 9-Structure and Parts List

### 9.1-Main column assembly

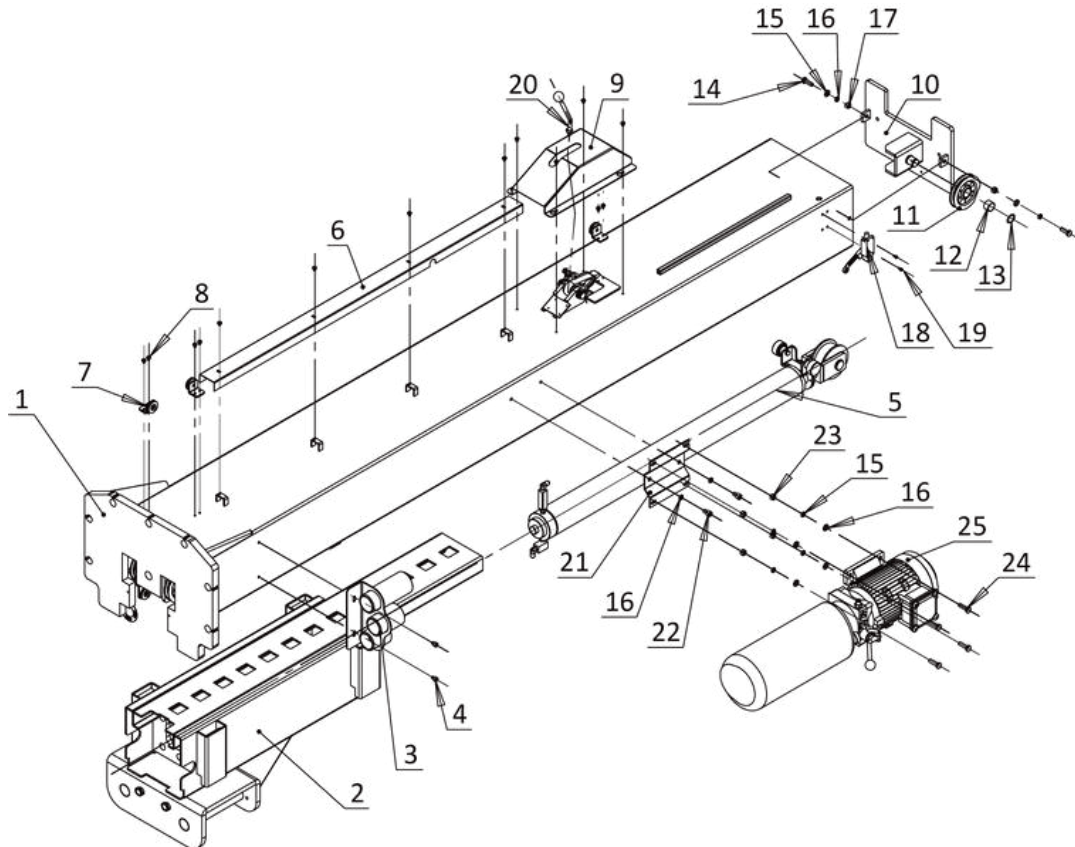

No.	Name	Qty.	No.	Name	Qty.
1	Main column assembly	1	14	Hex bolts M10×35	2
2	Carriage assembly	1	15	Spring cushion Φ10	6
3	Heightening set of bracket combination	1	16	Flat pad Φ10	8
4	Socket head cap screws M8×10	2	17	Hex nuts M10	2
5	Hydraulic cylinder	1	18	Limit switch 8108	1
6	Column buckle cover	1	19	Phillips round head screws M5×10	2
7	Unlock the sheave seat combination	3	20	Unlock lever	1
8	Phillips round head screws M6×8	14	21	Power unit backpack	1
9	Safety lock cover (opening)	1	22	Socket head cap screws M10×16	2
10	Upper cover welding	1	23	Hex nuts M10	4
11	Rope wheel	1	24	Hex bolts M10×35	4
12	Oil-free bearing	1	25	Power unit	1
13	Circlip Φ25	1			

## 9.2-Sub-column assembly

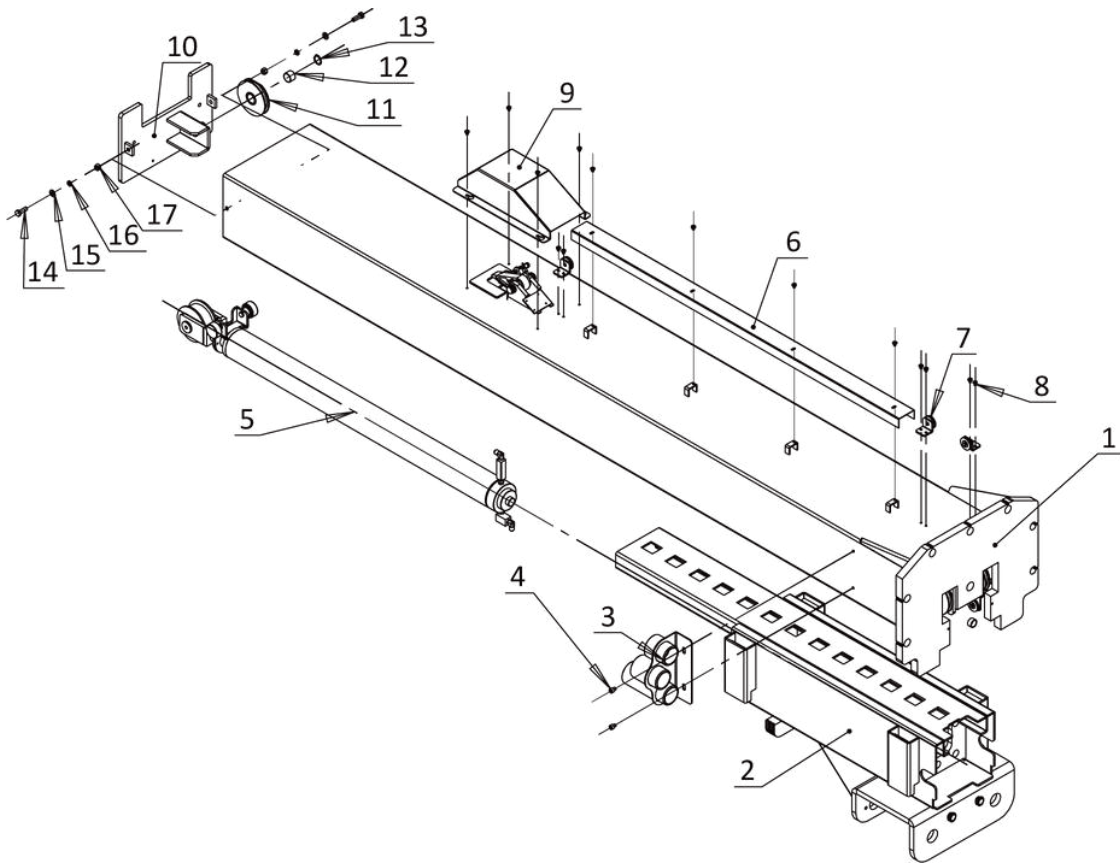

No.	Name	Qty.	No.	Name	Qty.
1	Sub-column assembly	1	10	Upper cover welding	1
2	Carriage assembly	1	11	Rope wheel	1
3	Heightening set of bracket combination	1	12	Oil-free bearing	1
4	Socket head cap screws M8×10	2	13	Circlip Φ25	1
5	Hydraulic cylinder	1	14	Hex bolts M10×30	2
6	Column buckle cover	1	15	Spring cushion Φ10	2
7	Unlock the rope seat combination	3	16	Flat pad Φ10	2
8	Phillips round head screws M6×8	14	17	Hex nuts M10	2
9	Safety lock cover	1			

### 9.3-Carriage assembly

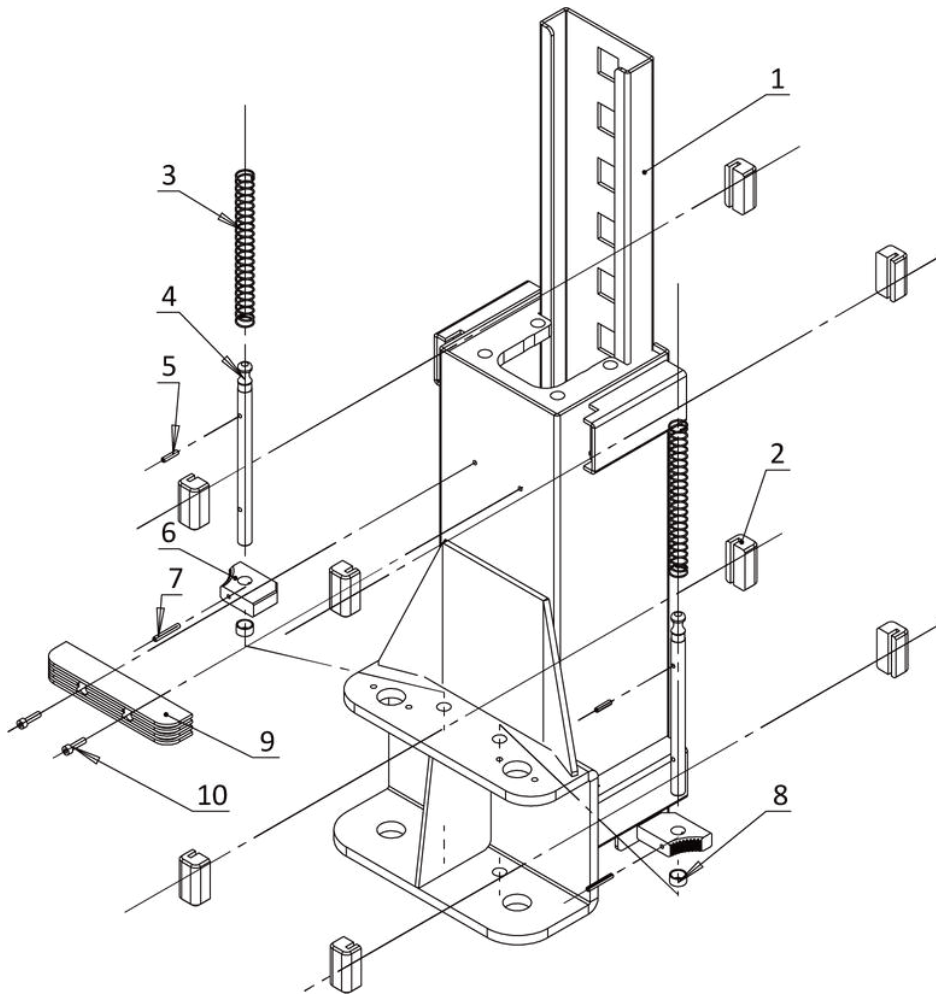

NO.	Name	Qty.
1	Carriage welding	1
2	Nylon slider	8
3	Arm lock spring	2
4	Arm lock shaft	2
5	Elastic cylindrical pin $\Phi 6 \times 22$	2
6	Square lock tooth	2
7	Elastic cylindrical pin $\Phi 6 \times 50$	2
8	Square gear shaft washer	2
9	Anti-collision tape	1
10	Socket head cap screws M8 $\times$ 30	2

### 9.4-Hydraulic cylinder assembly

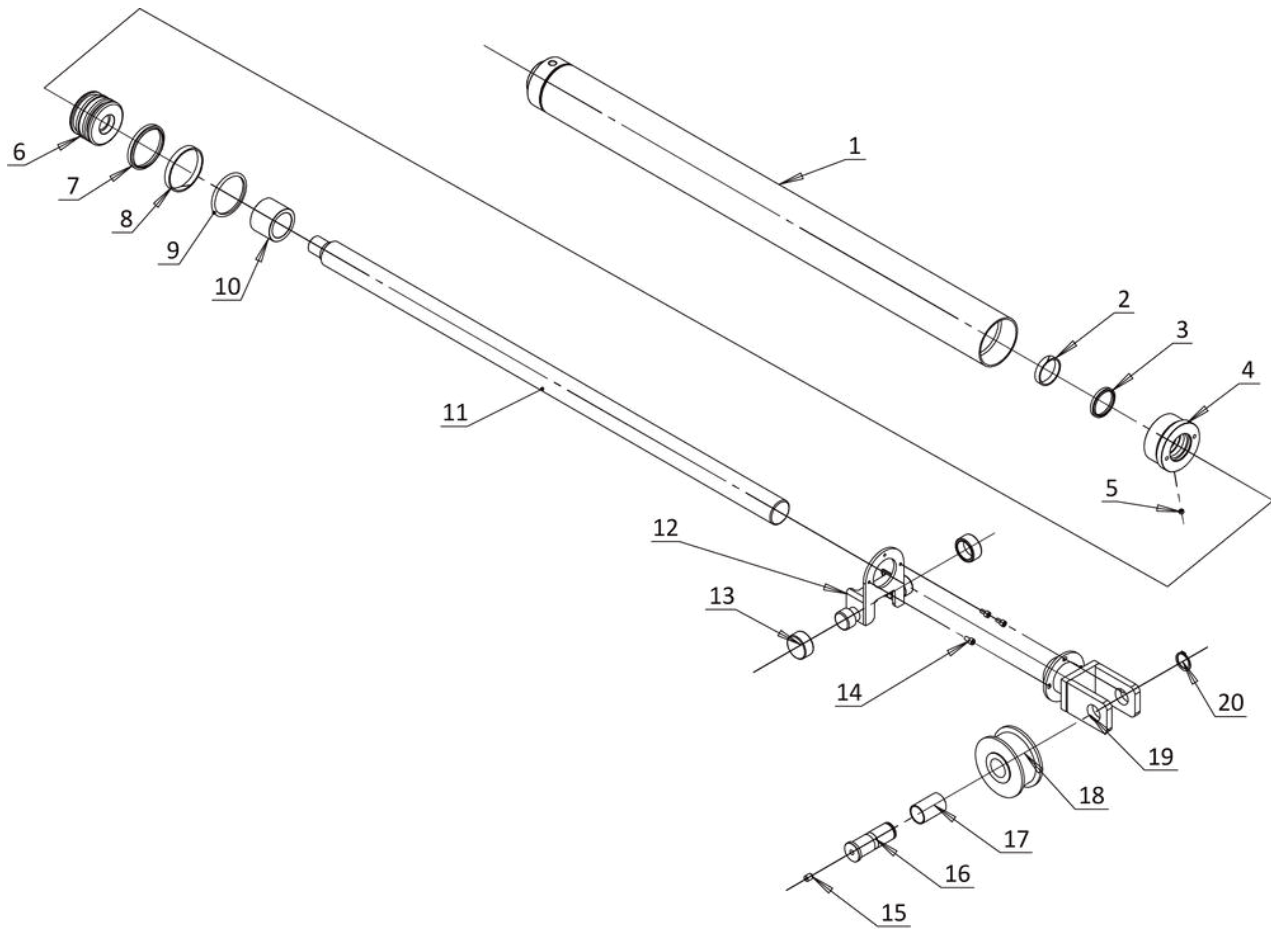

No.	Name	Qty.	No.	Name	Qty.
1	Welding of hydraulic cylinder	1	11	Cylinder piston rod	1
2	Liquid guide belt 10×2.5×160	1	12	Sprocket frame sleeve welding	1
3	Liquid dust ring DH45×5.3×5×6.5	1	13	Guide rollers	2
4	Cylinder head	1	14	Hexagon socket screw M6×12	3
5	Oil cylinder head filter	1	15	Grease cup	1
6	Cylinder piston	1	16	Sprocket shaft	1
7	Sealing ring UN70×80×10	1	17	Oil-free bearing	1
8	Liquid guide belt 10×2.5×270	1	18	Sprocket	1
9	O type rubber ring D69×5.7	1	19	Sprocket frame welding	1
10	Cylinder limit sleeve	1	20	Circlip Φ30	1

### 9.5-Main column safety lock assembly

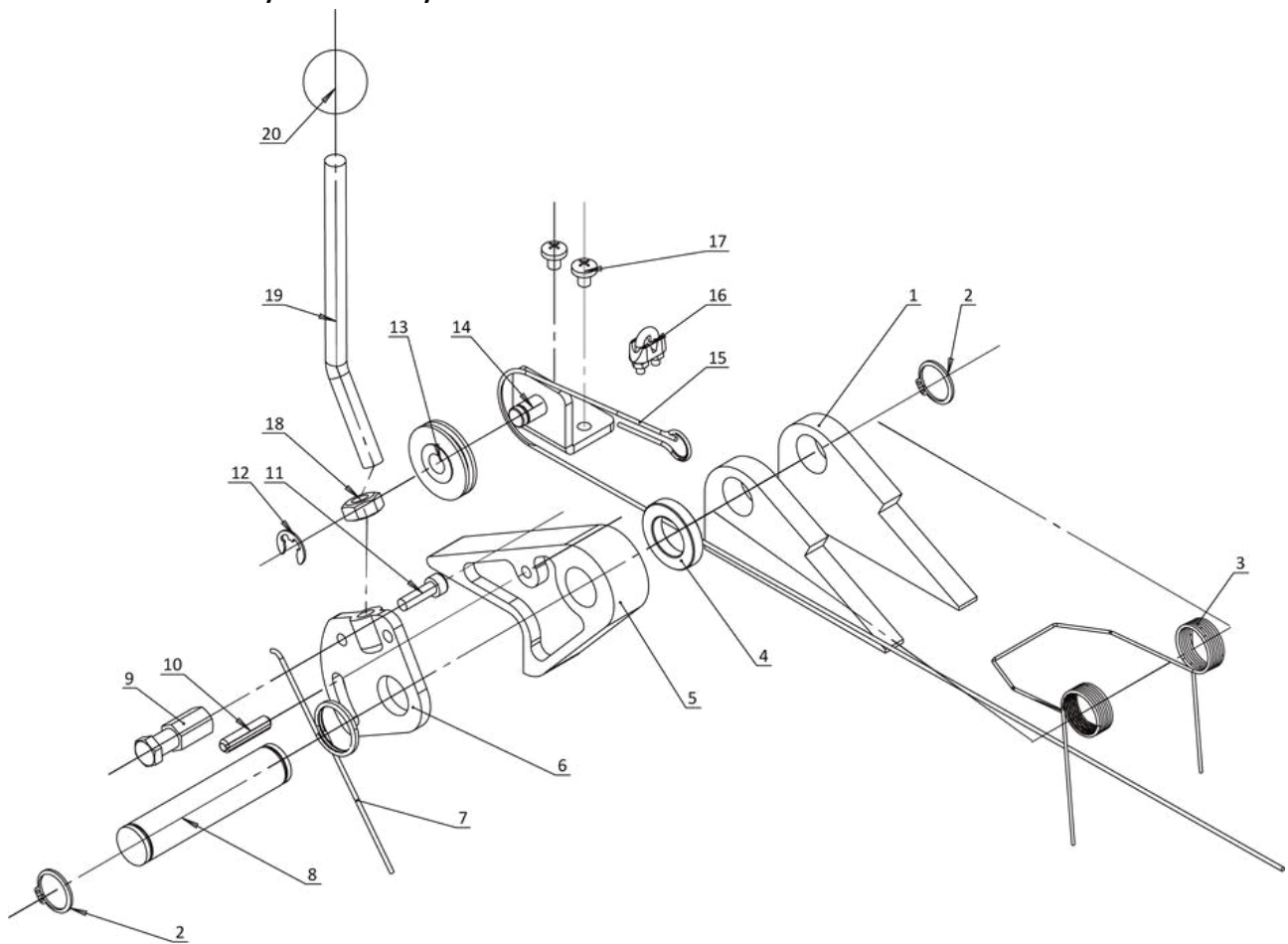

No.	Name	Qty.	No.	Name	Qty.
1	Security lock ears	2	11	Socket head cap screws M6×20	1
2	Circlip Φ20	2	12	Circlip Φ10	1
3	Door spring	1	13	Unlock the sheave	1
4	Security lock spacer	1	14	Unlock the sheave seat	1
5	Safety tip lock	1	15	Unlock the thin wire rope	1
6	Unlock the handle seat	1	16	U-shaped chuck	1
7	Torsion spring	1	17	Phillips round head screws M6×8	2
8	Safety lock shaft	1	18	Hex nuts M10	1
9	Unlock the rope seat	1	19	Unlock lever	1
10	Elastic cylindrical pin Φ6×30	1	20	Handball	1

### 9.6-Secondary column safety lock assembly

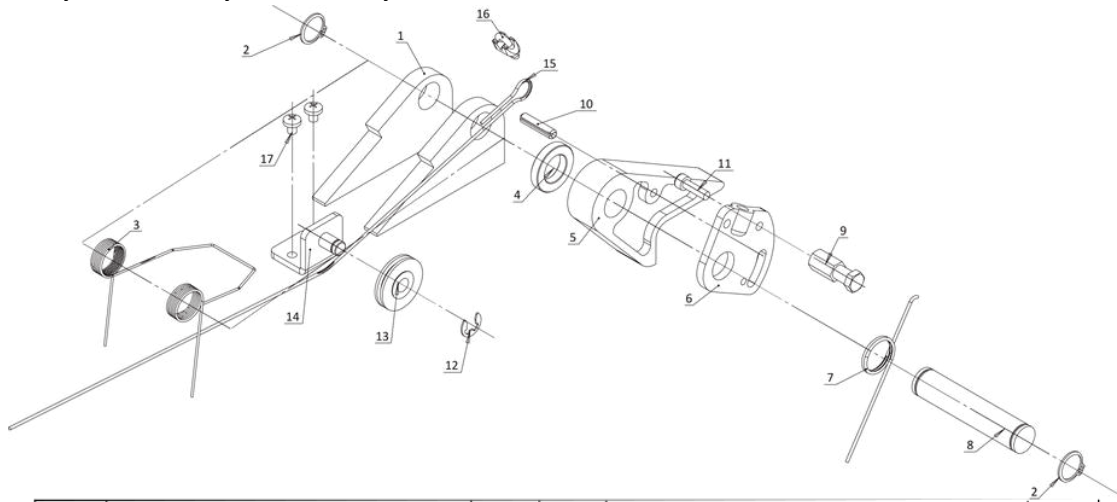

No.	Name	Qty.	No.	Name	Qty.
1	Security lock ears	2	10	Elastic cylindrical pin $\Phi 6 \times 30$	1
2	Circlip $\Phi 20$	2	11	Socket head cap screws M6 $\times$ 20	1
3	Door spring	1	12	Circlip $\Phi 10$	1
4	Security lock spacer	1	13	Unlock the sheave	1
5	Safety tip lock	1	14	Unlock the sheave seat	1
6	Unlock the handle seat	1	15	Unlock the thin wire rope	1
7	Torsion spring	1	16	U-shaped chuck	1
8	Safety lock shaft	1	17	Phillips round head screws M6 $\times$ 8	2
9	Unlock the rope seat	1			

### 9.7-Three-section arm assembly

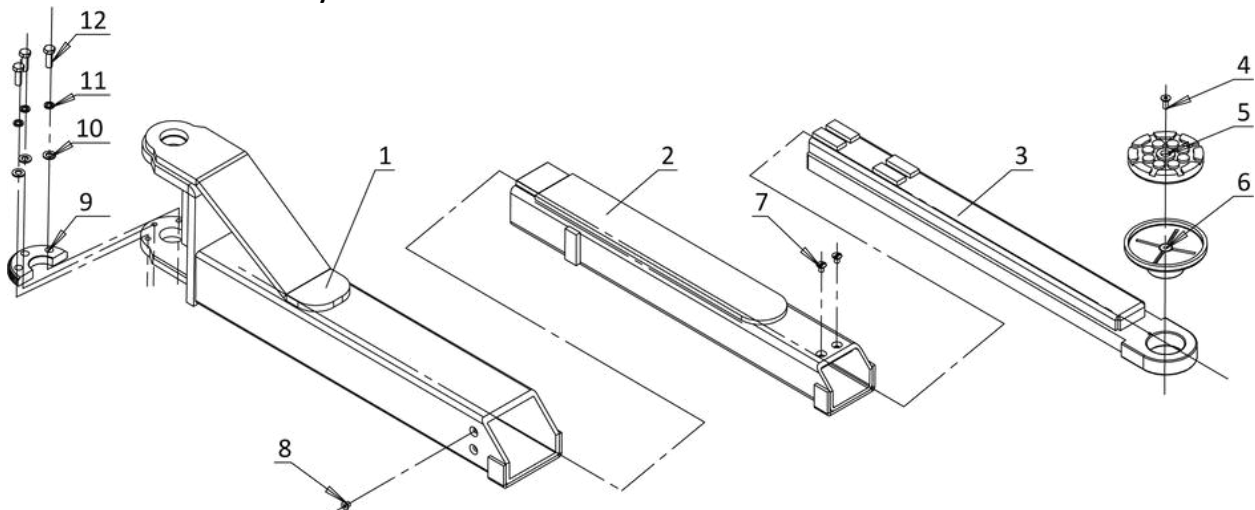

NO.	Name	Qty.	No.	Name	Qty.
1	Three-section support arm big arm welding	1	7	Flat head hexagon socket screw M8 $\times$ 10	2
2	Three-section support arm middle arm welding	1	8	Socket head cap screws M10 $\times$ 12	1
3	Three-section support arm forearm welding	1	9	Moon teeth	1
4	Flat head hexagon socket screw M8 $\times$ 16	1	10	Flat pad $\Phi 10$	3
5	Round rubber pad	1	11	Spring cushion $\Phi 10$	3
6	Pallet welding	1	12	Hex bolts M10 $\times$ 30	3



## Special Notes

### **Environmental damage :**

- Only appropriately trained personnel may dismantle and dispose of the unit.

### **Dismantling:**

- To dismantle the product, proceed as follows:

#### **ELECTRICAL HAZARD!**

- When carrying out any decommissioning and dismantling work on the unit, switch off all power supply connections, ensure they cannot be switched on unintentionally and verify that they have been disconnected. Earth and short-circuit them, and cover or otherwise isolate any neighboring live parts. Failure to do so may lead to serious injuries or death.

#### **HIGH PRESSURE HAZARD.**

- When carrying out any unit decommissioning and dismantling work, close off and empty all the connection pipes until the pressure is the same as the ambient air pressure. Failure to do so may lead to injury.
- Make sure that the hydraulic circuit has been switched off. Close all hydraulic shut-off valves.
- Disconnect all connections, making sure at the same time, that no operating materials escape, such as oil, refrigerant and water- glycol mixture.
- Loosen the connection to the base.

#### **PERSONAL INJURY!**

- Secure the unit against slipping. The unit is ready for transporting.
- It is important that all transport information is observe

### **Disposal:**

- A specialist company with the appropriate competence must dispose of the unit and individual components. This technical services department must ensure that:
  - the components are separated according to material types
  - that the operating materials are sorted and separated according to their properties.

#### **ENVIRONMENTAL DAMAGE.**

- Dispose of all components and operating materials (such as oil, refrigerant and water-glycol mixture) separately according to material and in line with local laws and environmental regulations.

### **Noise Declaration:**

- Sound power level: LWA<85dB Accompanied uncertainly K=4 dB
- With the rated load, the pump motor rotate.
- Applied operating conditions are:
- According to the test report, the operating position is the loudest, but the noise risk is not a hazard, as the volume should not be high enough to hurt the operator.
- If the volume is higher than 85 dB, the lift must be stopped and check for troubles and repairs.



# Important Safety Instructions

## 1.1 Important Notices

- Make sure to pay careful attention to the label of the lifting capacity attached on the lift and never try to lift cars above the lifting capacity labeled.
- Read this manual carefully before operating the machine so as to avoid personnel injury
- Users are not permitted to make any modification to the control or mechanical unit

## 1.2 Qualified Personnel

- Only properly trained individuals are permitted to operate the lift.

## 1.3 Warning Signs

- All safety warning labels are clearly depicted on the lift to ensure that the operator is aware of and avoids the dangers of using the lift in an incorrect manner. The labels must be kept clean and they have been replaced if detached or damaged. Please read the meaning of each label carefully and understand them for future operation

## 1.4 Safety Instructions

- Make sure that you have read the User's Manual completely, including relevant instructions on installation, operation, and safety before operating the lift.
- This lift is designed for lifting vehicles 12,000 LBS and under. Any other use may result in damage of the lift or injury to personnel.
- Only those who have been properly trained should operate the lift. Customers or inexperienced persons should be prohibited from operating the lift at will.
- Do not load the lift beyond its rated capacity. To reduce the risk of injury, refer to loading instructions, and never attempt to lift more than the rated capacity.
- The lift is designed to lift the entire body of vehicles with weight within the lifting capacity.
- If the lift is designed for indoor use only, outdoor use is prohibited.
- Do not install the lift on any surface other than concrete that is at least 6" thick and has set for at least 30 days.
- Do not move away from controls while lift is in motion.
- Keep hands and feet away from any moving parts, do not put hands in any dangerous places, such as the space between tool arms.
- Do not wear any loose clothing that could be caught in moving parts. Keep hair, fingers, and all body parts away from moving parts. Always wear appropriate safety equipment during operation.
- Keep area around the lift clean to avoid incidents. Any oil stain or obstacle may pose a safety risk.
- Always ensure the safety latches are operational before any attempt to work near or under the vehicle.
- Always ensure the safety locks are engaged before any attempt to work near or under the vehicle.
- Never remove safety related components from the lift.
- Do not use if safety related components are damaged or missing
- Ensure all regular maintenance is completed. If anything abnormal occurs, stop using the lift and immediately contact us for help.
- Do not rock the vehicle while on the lift or remove heavy components that may cause weight shift, as the vehicle could fall.
- Do not modify any part of the lift without manufacturer's advice; THIS VOIDS THE WARRANTY and increases the chances of injury or property damage.
- If the lift is not in use, lower to the lowest position and disconnect power.
- It is prohibited to lift the vehicle while occupied.
- When a vehicle is being loaded or unloaded from the lift, no person is allowed to stand in the vehicle passage.
- Do not use the lift while tired, or under the influence of drugs, alcohol, or medications

- Keep areas well lit.
- Keep loads balanced on the lift platforms. Clear the area immediately if a vehicle is in danger of falling off the lift. **DO NOT ATTEMPT TO CATCH A FALLING VEHICLE!**
- Make sure there are no obstacles under the vehicle before lowering it
- If the lift will be left unused for a long period of time, it is recommended that the user disconnects power, empties the oil tank, and lubricates any moving parts with hydraulic oil

**Attention: For environment protection, please dispose of the used oil in a proper way.**



## WARNING:

1. The warning, cautions and instructions discussed in this manual cannot cover all possible conditions and situations that may occur. It must be understood by the operator that common sense and caution are factors which cannot be built into this product, but must be supplied by operator.
2. ALWAYS ensure the mechanical safety locks are engaged. Never remove safety related components from the lift. Do not use if safety related components are damaged or missing.
3. Failure to correctly install, operate, or any improper modifications could result in injury or death of operators.

### 1.5 Labels

A	<b>STRATUS</b> auto equipment		STRATUS AUTO EQUIPMENT www.stratusautoequip.com sales@stratusautoequip.com Tel: 512-640-9896		CE	
	MODEL:		DATE:			
	SERIAL NO.					
	Lifting Capacity:		lbs	Rated Voltage:		V
	Lifting Height:		in	Rated Frequency:		Hz
	Min Height:		in	Phase:		Ph
	Platform Length:		in	Net Weight:		lbs

**B**

 <b>CAUTION</b> 	
<ul style="list-style-type: none"><li>• Only trained personnel is allowed to use the lift.</li><li>• Read the entire manual before operating</li><li>• Never try to raise the vehicle exceeding lift capacity</li><li>• Make sure you meet all safety requirements before you start working under the vehicle</li><li>• Surrounding of lift will remain clear when raising or lowering</li><li>• The manufacturer and distributor will not take any responsibility if user does not follow the operation manual that comes with the lift</li></ul>	

**C**









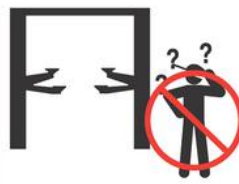

	 <b>CAUTION</b>
Keep feet clear of the lift when lowering	

**D**

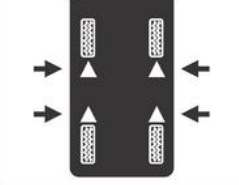
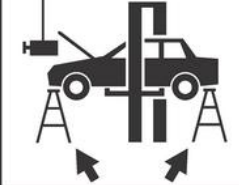
	 <b>CAUTION</b>
Make sure the mechanical safety has been locked before working under the car	

**E**

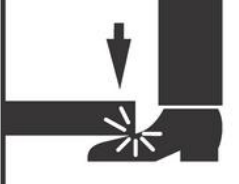

<p><b>⚠ CAUTION</b></p>  <p>Lift to be used by trained operator only.</p> <p>©</p>	<p><b>⚠ CAUTION</b></p>  <p>Authorized personnel only in lift area.</p> <p>©</p>	<p><b>⚠ WARNING</b></p>  <p>Clear area if vehicle is in danger of falling.</p> <p>©</p>	<p><b>⚠ WARNING</b></p>  <p>Position vehicle with center of gravity midway between adapters.</p> <p>©</p>
<p><b>⚠ CAUTION</b></p>  <p>Use vehicle manufacturer's lift points.</p> <p>©</p>	<p><b>⚠ CAUTION</b></p>  <p>Always use safety stands when removing or installing heavy components.</p> <p>©</p>	<p><b>⚠ WARNING</b></p>  <p>Remain clear of lift when raising or lowering vehicle.</p> <p>©</p>	<p><b>⚠ WARNING</b></p>  <p>Avoid excessive rocking of vehicle while on lift.</p> <p>©</p>
<p><b>⚠ CAUTION</b></p>  <p>Use height extenders when necessary to ensure good contact.</p> <p>©</p>	<p><b>⚠ CAUTION</b></p>  <p>Auxiliary adapters may reduce load capacity.</p> <p>©</p>	<p><b>⚠ WARNING</b></p>  <p>Do not override self-closing lift controls.</p> <p>©</p>	<p><b>⚠ WARNING</b></p>  <p>Keep feet clear of lift while lowering.</p> <p>©</p>
<p>The messages and pictographs shown are generic in nature and are meant to generally represent hazards common to all automotive lifts regardless of specific style.</p> <p>Replacement label sets may be obtained from the original lift manufacturer and ALI's member companies.</p> <p>Funding for the development and validation of these labels was provided by the Automotive Lift Institute, PO Box 85, Cortland, NY 13045. These labels are protected by copyright.</p> <p>www.autolift.org      © 2006-2017      ALI/WL101</p>		<p>The messages and pictographs shown are generic in nature and are meant to generally represent hazards common to all automotive lifts regardless of specific style.</p> <p>Replacement label sets may be obtained from the original lift manufacturer and ALI's member companies.</p> <p>Funding for the development and validation of these labels was provided by the Automotive Lift Institute, PO Box 85, Cortland, NY 13045. These labels are protected by copyright.</p> <p>www.autolift.org      © 2006-2017      ALI/WL101</p>	

**\*Warning label pictographs used with permission of the Automotive Lift Institute.**

## 1.6 Sound Level

- The sound emitted from the lift should not exceed 75 DB.

## 1.7 Special Reminder

- The newly installed lift can NOT directly lift vehicle, and should be raised to the highest point then lowered to the lowest point 2-3 times repeatedly without any load to bleed the air out from the hydraulic hose and cylinders to ensure the lift runs smoothly
- 1st time use of the lift with a load after bleeding air out of the the hydraulic hose and cylinders should follow the steps below
  - Loosen the screw cap of the hydraulic oil flow valve and tighten the middle hexagonal screw clockwise inward to the tightest position.
  - Press the “UP” button to raise the lift with loaded vehicle to your desired height.
  - Press and hold the “DOWN” button to wait for the safety lock to be disengaged, then adjust the hydraulic oil flow valve (the middle hexagonal screw) by turning the screw counterclockwise to make the lowering speed reach .5 in/sec or slower.

## Truck Adapters

All Stratus 2-Post lifts are compatible with the following truck adapters only. - Screw-Up Pad Extension - Height Extension Adapter



### **\*WARNING\***

The truck adapters cannot be stacked or used with other adapters. All Stratus adapters should only be used along with the appropriate components.



The Height Extension Adapter can only be used with the designated pad and CANNOT be stacked with any other adapter. See Fig. 3



Fig.3



Fig. 2

The Height Extension Adapter should only be used with the appropriate extension as shown above in Fig. 2

The Screw-Up Pad can only be used with the locking adapter as shown above on Fig. 1.

**Stratus Auto Equipment shall not be liable for any injuries or death arising from the mis- use of the lift or any of its accessories, including, but not limited to, truck adapters, height extension adapters, and similar components. Users acknowledge and accept full responsi- bility for the proper use and handling of the equipment.**